

ANNEX 12

Specific construction and calculation aspects of one-way floor slabs with precast beams and hollow-core slabs

1 Scope

This Annex aims to provide additional rules on the construction and calculation aspects of one-way floor slabs consisting of precast elements and site-cast concrete.

2 Definition of the constituent elements of a floor slab

- Joist: loadbearing longitudinal element, precast at a permanent facility off site, designed to support loads produced on floor slabs for intermediate floors or roofs. They may be reinforced or prestressed.
- Prestressed hollow-core slab: flat surface element made of prestressed concrete, precast at a permanent facility off site, lightened by means of longitudinal voids and designed to support loads produced on floor slabs. The side joints are specially designed so that, once filled with concrete, they can transmit the shear stresses to adjacent slabs.
- Infill block: precast element made of brick, concrete, expanded polystyrene or other suitable materials, with a lightening or collaborating function, intended to form part, together with the beams, site-cast top slab and structural reinforcements, of the loadbearing assembly of a floor slab.
- Concrete top slab: element formed of site-cast concrete and reinforcements, intended to distribute the various loads applied to the floor slab and other additional functions as required (diaphragm action, bracing and tying, strength through the formation of a compound section, among others).

3 Types of floor slab

3.1 Joist floor slab

Construction system consisting of:

- a) precast concrete or concrete and brick joists, reinforced or prestressed,
- b) infill blocks whose function may be to lighten the structure or collaborate in providing strength,
- c) structural reinforcements, whether longitudinal, transverse or intermediate, placed prior to concreting, and
- d) site-cast concrete for filling ribs and forming the top slab of the floor slab.

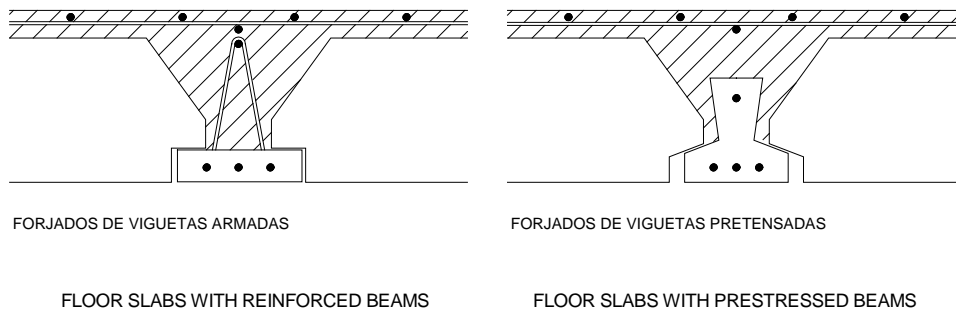

Figure A.12.3.1 Usual types of joist floor slabs

3.2 Prestressed hollow-core floor slab

Construction system consisting of:

- precast hollow-core slabs made of prestressed concrete,
- site-placed reinforcement, where applicable, and
- site-cast concrete for filling side joints between slabs and forming the top slab, where applicable, in accordance with Article 59.2.1 of this Code.

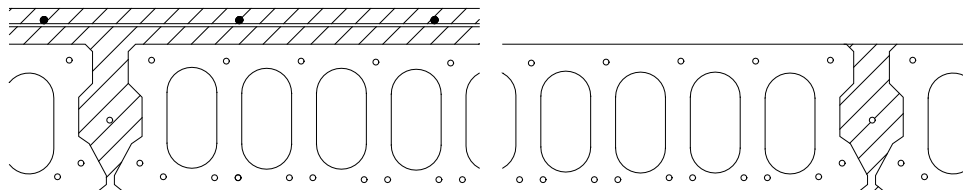
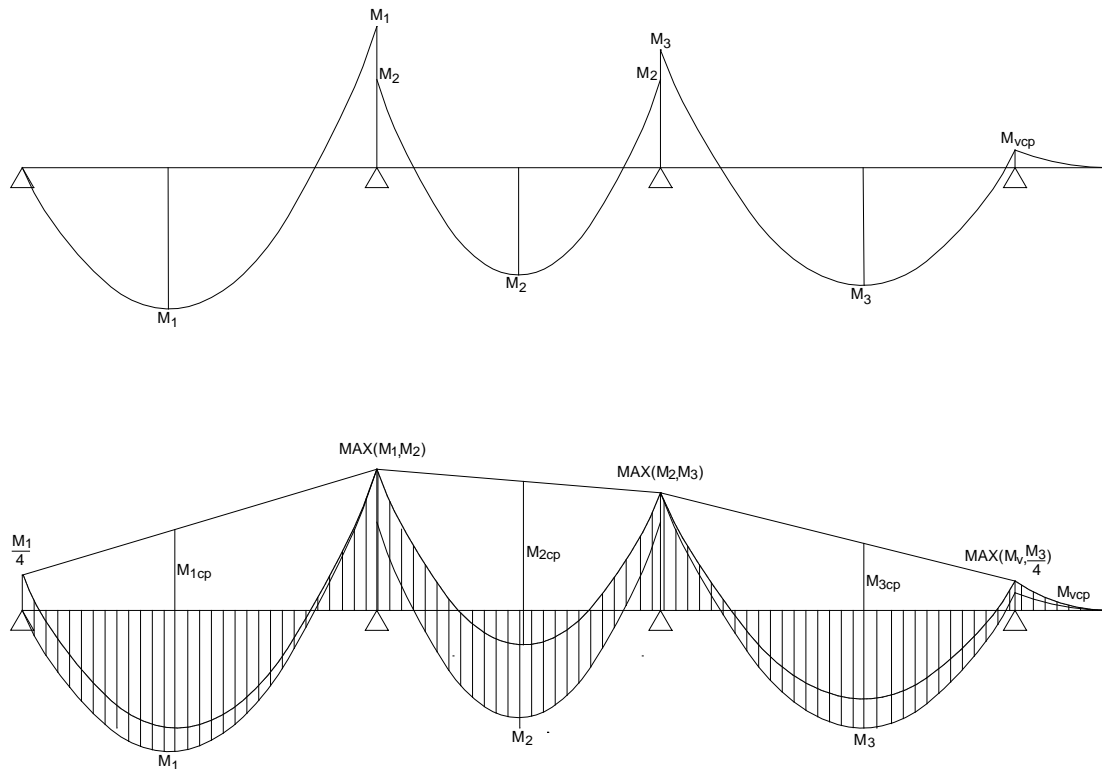

Figure A.12.3.2 Usual types of prestressed hollow-core floor slabs

4 Simplified method for redistributing stresses in floor slabs

The stresses with the maximum permitted redistribution for floor slabs can be determined using the simplified method set out below. In the basic graph of the maximum bending moment of each section (Figure A.12.4.a), the moments for the total load according to the following criteria are calculated:

- in the end stretches, a moment will be taken as equal to the moment of its internal support (M_1 or M_3);
- in the intermediate stretches, a moment will be taken as equal to the moment of both supports (M_2);
- in the end support, a moment will be taken as zero if there is no cantilever and, if there is, as the moment due to the permanent loads on this cantilever (M_{vcp}).



Figures A.12.4.a and b. Basic and envelope graphs of bending moments

The values of the moments M_1 , M_2 and M_3 for uniformly distributed loads determined analytically are:

$$M_1 = (1,5 - \sqrt{2}) p_1 l_1^2$$

$$M_2 = \frac{p_2 l_2^2}{16}$$

$$M_3 = \left(1,5 + \frac{M_v}{p_3 l_3^2} - \sqrt{2 + \frac{4M_v}{p_3 l_3^2}} \right) p_3 l_3^2$$

Determining the negative bending moment at each support from the basic graph: In the end supports, this is taken as equal to one-quarter of the positive moment of the adjacent section calculated using the assumption of articulation at the end, or as the moment of the cantilever due to the total load (M_v), where this exists and where it is higher. In the inner supports, this is taken as the highest of the positive moments of the adjacent sections.

The envelope graph of bending moments (Figure A.12.4.b) is determined by superimposing, onto the basic graph, the graph of the bending moments of the permanent loads of each section, determined from the negative moments taken into account in the corresponding supports.

The shear stresses are taken as those corresponding to the bending moments in Figure A.12.4.b.

The vertex of the diagram of negative bending moments, in the case of flat beams or flanges of very wide compound beams, may only be subject to parabolic rounding if the stress concentration effect in the vicinity of the support is simultaneously taken into account; this fact is particularly important when the width of the support is much less than that of the beam.

For the purposes of the above, the effective width of the flat beam must be limited to the width of the support plus 1,5 times the beam depth on each side of the support.

Floor slabs without straining pieces and particularly prestressed hollow-core slabs, under the self-weight of the floor slab, including the site-cast concrete top slab, where applicable, must be regarded as double-supported elements. Only for the other permanent loads and the overload will the continuity be taken into account.

5 Transverse distribution of loads in one-way floor slabs and hollow-core slabs

5.1 Transverse distribution of linear and point loads in joist floor slabs

In joist floor slabs, account must be taken of the surface loads caused by the self-weight of the floor slab, flooring, covering, partitioning and service load and also, where these exist, linear loads caused by walls and heavy partitions (larger than a thick partition) and, where applicable, point or localised loads.

In roof slabs, account must be taken of the surface loads caused by the self-weight of the slab, including infill or boarding with partitions, flooring or roofing, insulation, coverings, snow or service load if this is more unfavourable and, where applicable, wind load. In addition, linear, point or localised loads shall be taken into account where these exist.

Partitioning and flooring may be taken into account as permanent loads and therefore, in general, the study of their section-by-section variation is not required.

The distribution of point loads basically situated in the centre of the length of an inner joist, or linear loads parallel to these, in the absence of more precise calculations, can be determined in a simplified manner by multiplying the load by the factors indicated in Table A.12.5.1:

Table A.12.5.1 Transverse distribution factors for point or linear loads

Joist	1	2	3	4
Factor	0,30	0,25	0,15	0

In this case, the site-cast top slab must be reinforced to withstand a moment equal to:

$$0,3 p_d, \quad \text{for linear loads;} \\ 0,125 P_d, \quad \text{for point loads;}$$

where:

P_d Design point load, in kN;
 p_d Design linear load, in kN/m, per m of beam.

This reinforcement must extend in the direction of the joists up to a distance of $L/4$ from the point load and the same length from the ends of the loaded zone in the case of a linear load and in the direction perpendicular to these until reaching beam 4 in Figure A.12.5.1.

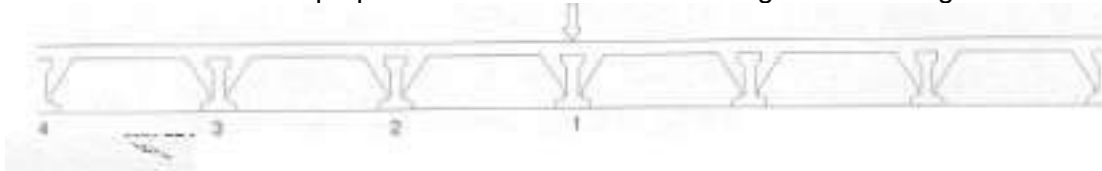

Figure A.12.5.1 Transverse distribution of point or linear loads

5.2 Transverse distribution of linear and point loads in prestressed hollow-core floor slabs

5.2.1. Calculation method

Two calculation methods may be used which involve load distribution according to the elasticity theory and no load distribution.

The first method must only be used when lateral displacements are limited as stipulated in section 5.2.3 of this Annex. Otherwise, the calculation must be carried out according to the second method.

The linear loads parallel to the edge of the elements and no greater than 5 kN/m may be replaced by a load uniformly distributed over a width equal to one-quarter of the span on both sides of the load. If the available width next to the load is less than one-quarter of the span, the load must be distributed over a width equal to that available on one side, plus one-quarter of the span on the other side.

5.2.1.1. Distribution of the load according to the elasticity theory

The elements shall be regarded as isotropic or anisotropic slabs and the longitudinal joints as hinges.

The percentage of the load on the directly loaded element, determined from the calculation, must be multiplied, in the Ultimate Limit State, by a factor of $\gamma = 1,25$; the total percentage of the load transmitted via the adjacent elements may be reduced by the same quantity and is distributed between the various elements according to their corresponding load percentages.

As an alternative to the analytical determination, the transverse load distribution may be determined using graphs based on the elasticity theory. Sections 5.2.4 and 5.2.5 provide graphs for slabs with a width $b = 1,20$ m.

5.2.1.2. No load distribution

Each element must be designed taking into account that all the loads act directly on this element, assuming zero shear in the transverse joints. In this case, the transverse load distribution and the associated torsional moments can be ignored in the Ultimate Limit State. However, in the Serviceability Limit State, the requirements laid down in sections 6.1 and 6.2 of this Annex must be met. The effective width must be limited in accordance with section 5.2.2 of this Annex.

5.2.2. Limitation of the effective width

If the Ultimate Limit State calculation is based on the second method defined in section 5.2.1.2 (no load distribution), for point loads and for linear loads with a characteristic value greater than 5 kN/m, the maximum effective width must be limited to the width of the load increased by:

- a) In the case of loads inside the floor slab, double the distance between the centre of the load and the support, but never more than half the width of the loaded element.
- b) In the case of loads on free longitudinal edges, once the distance between the centre of the load and the support, but no more than half the width of the loaded element.

5.2.3. Limitation of lateral displacements

If the design is based on the method defined in section 5.2.1.1 for load distribution according to the elasticity theory, the lateral displacements must be limited by:

- a) The members surrounding the structure,
- b) Friction in the supports,

- c) Reinforcement at the transverse joints, and
- d) The perimeter ties.

In situations without any seismic risk, as laid down in the Earthquake-Resistant Construction Standard, only friction in the supports is needed, if it is proven that sufficient friction can develop. When calculating the friction resisting forces, the actual form of the support must be taken into account.

The strength required must be at least equal to the total vertical shear stresses which must be transmitted through the longitudinal joints.

5.2.4. Load distribution factors for loads at the centre and edges

- a) Figures A.12.5.2.4.a, A.12.5.2.4.b and A.12.5.2.4.c contain graphs showing the load percentages for a centred load and an edge load. A load may be regarded as a centred load if the distance from this to the edge of the floor slab area is $\geq 2,5$ times the width of the prestressed hollow-core slab (≥ 3 m). For loads between the edge and the centre, the load percentages can be determined by linear interpolation.
- b) Figures A.12.5.2.4.b and A.12.5.2.4.c contain graphs showing the distribution factors for point loads at the centre of the span ($l/x = 2$). For loads close to the support, $l/x \geq 20$, the load percentage assigned to the directly loaded slab must be taken as equal to 100%; for slabs not directly loaded, the load percentages must be taken as equal to 0%. For values of l/x between 2 and 20, the load percentages can be determined by linear interpolation.
- c) When determining the load percentages, linear loads with a length greater than half the span must be regarded as linear loads. Linear loads with a length less than half the span must be regarded as linear loads if the centre of the load is in the middle of the span and as point loads in the centre of the load if the centre of this is not in the middle of the span.
- d) In prestressed hollow-core floor slabs without a site-cast top slab, the load percentages, determined using the graphs, must be modified, in the Ultimate Limit State, as follows:
 - The load percentage on the directly loaded element must be multiplied by a factor of $\gamma_M = 1,25$;
 - The total percentages of the elements not directly loaded may be reduced by the same quantity according to the ratio of their load percentages.

The shear stresses at the joints must be calculated using the load percentages and shall be regarded as distributed linearly. For point loads not situated in the middle of the span and for linear loads which, according to point c), must be regarded as point loads, the effective length of the joint transmitting the shear stress must be taken as double the distance from the centre of the load to the closest support (see Figure A.12.5.2.4.d).

- e) The longitudinal shear stresses at each joint may be determined using the load percentages given in the graphs. Using these shear stresses, the torsional moments in each element can be determined.

If the lateral displacements are limited according to paragraph 5.2.3, the torsional moments can be divided by a factor of 2.

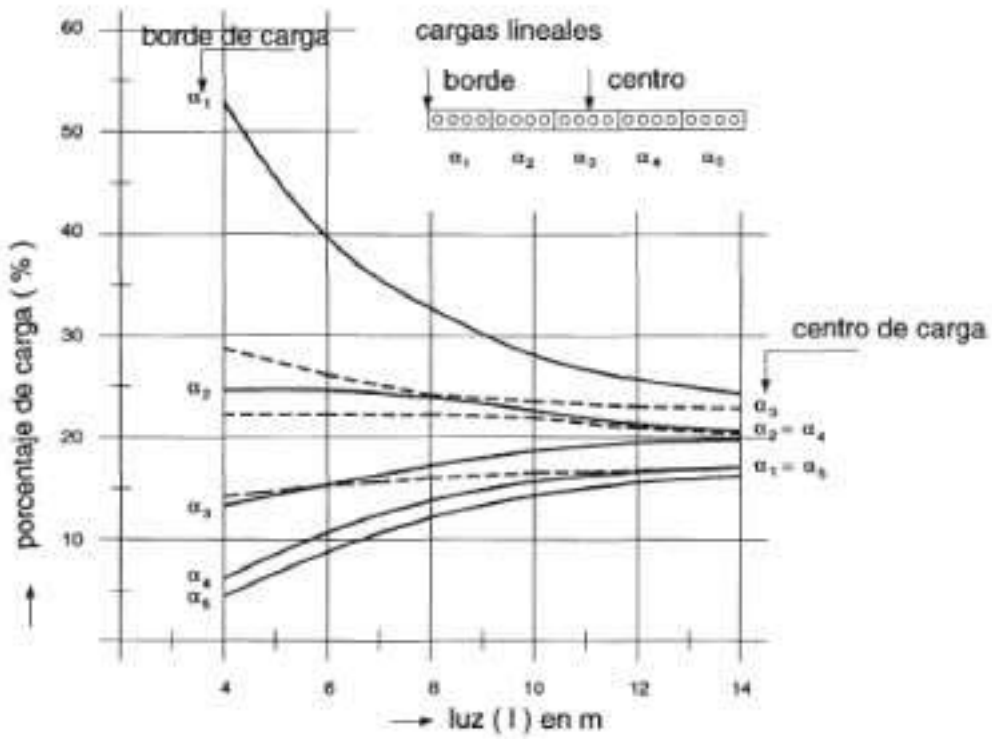

edge of load

linear loads

edge

centre

load percentage (%)

centre of load

span (l) in m

Figure A.12.5.2.4.a

Load distribution factors for linear loads ($b=1,20\text{ m}$)

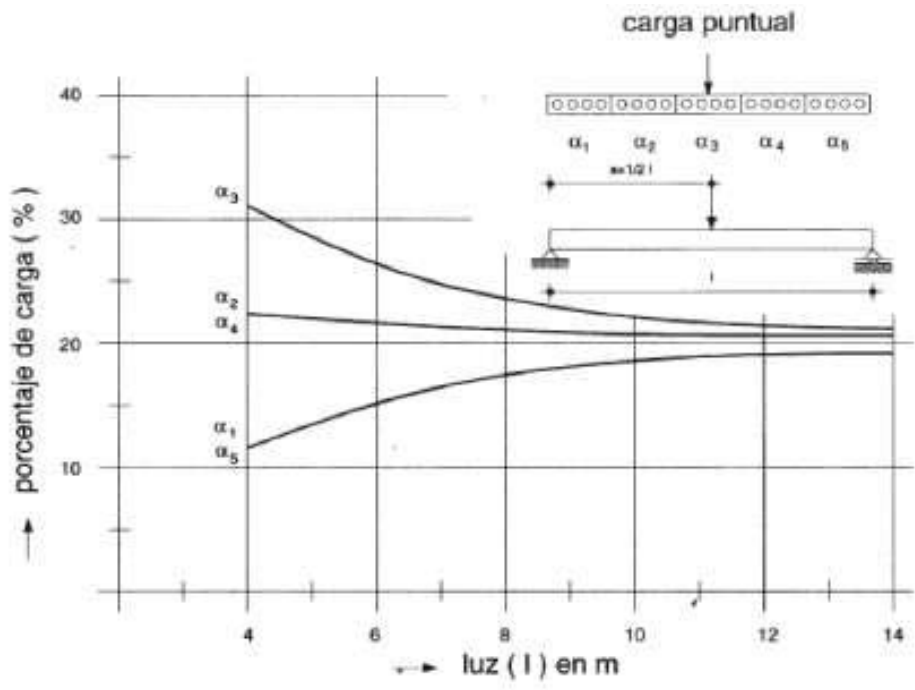

point load
 load percentage (%)
 span (l) in m

Figure A.12.5.2.4.b Load distribution factors for point loads centred in the width ($b=1,20$ m)

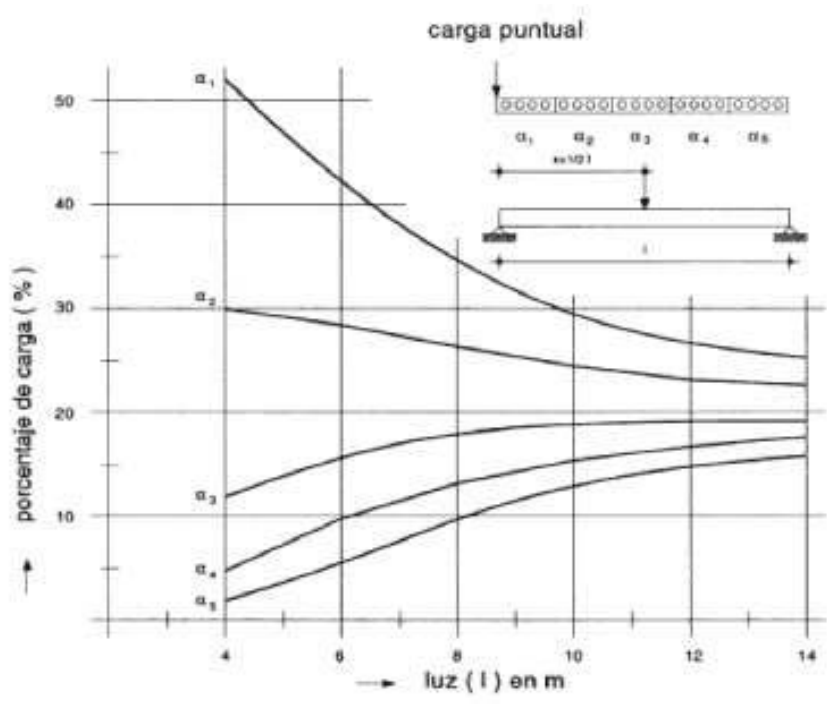

point load
 load percentage (%)
 span (l) in m

Figure A.12.5.2.4.c Load distribution factors for point loads at the edge ($b=1,20$ m)

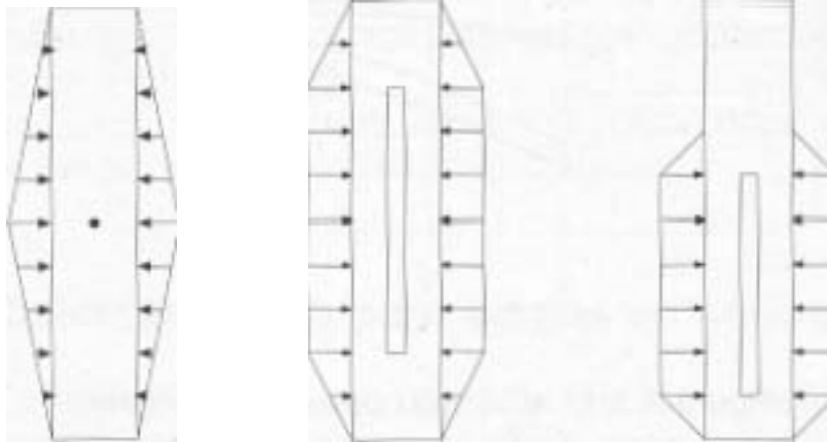

Figure A.12.5.2.4.d Assumed forms of the vertical shear stresses at the joints

5.2.5. Load distribution factors for three supported edges

- a) For linear and point loads, the reaction forces may be based on Figures A.12.5.2.5.a and A.12.5.2.5.b. If the number of elements n is greater than 5, the reaction force must be multiplied by the factor (see Figures A.12.5.2.5.a and A.12.5.2.5.b):

$$1 - \left(\frac{n-5}{50} \frac{s}{b} \right)$$

where s is the distance between the load and the support, in mm.

In the case of four supported edges, the reaction force of the support closest to the force must be multiplied by the factor:

$$\frac{nb-s}{nb}$$

- b) If the distance between the load and the longitudinal support is greater than 4,5 times the slab width (b), the reaction force may be taken as equal to zero.
- c) When determining the reaction forces, linear loads with a length greater than half the span must be regarded as linear loads. Linear loads with a length less than half the span shall be regarded as linear loads if the centre of the load is in the middle of the span and as point loads if the centre of the load is not in the middle of the span. The reaction force in Figure A.12.5.2.5.a may be multiplied by the ratio between the length of the load and the length of the span.
- d) For point loads in the middle of the span, $l/x = 2$, the reaction forces may be determined from Figure A.12.5.2.5.b. For loads near to the support, $l/x \geq 20$, the value of zero must be taken as the reaction force; for values of l/x between 2 and 20, these reaction forces must be calculated by linear interpolation. The length of the reaction force must be taken as equal to double the distance between the centre of the load and the closest support. The magnitude of the force is the value in Figure A.12.5.2.5.b multiplied by $2x/l$.
- e) The transverse distribution caused by the reaction force must be calculated according to paragraph 5.4, with the reaction force being regarded as an edge load (negative).

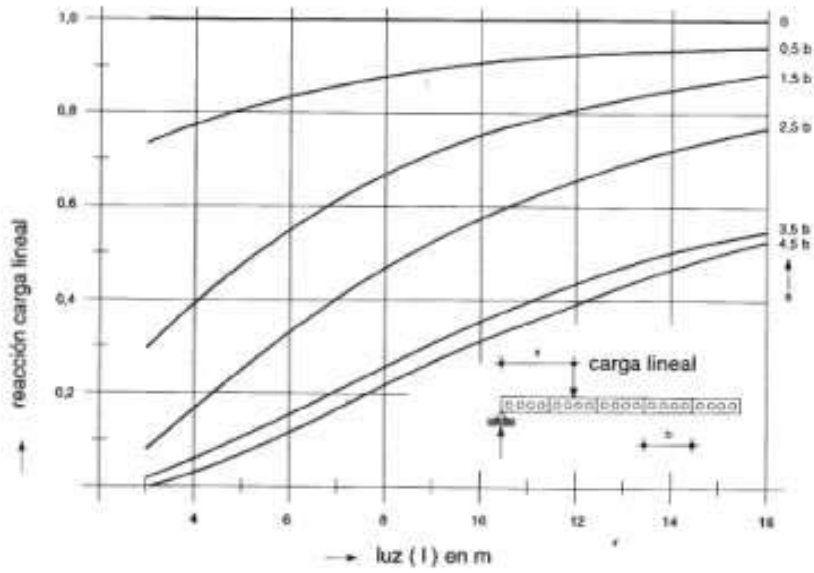

linear load reaction

linear load

span (l) in m

Figure A.12.5.2.5.a

Reaction force in the longitudinal support due to a linear load ($b=1,20$ m)

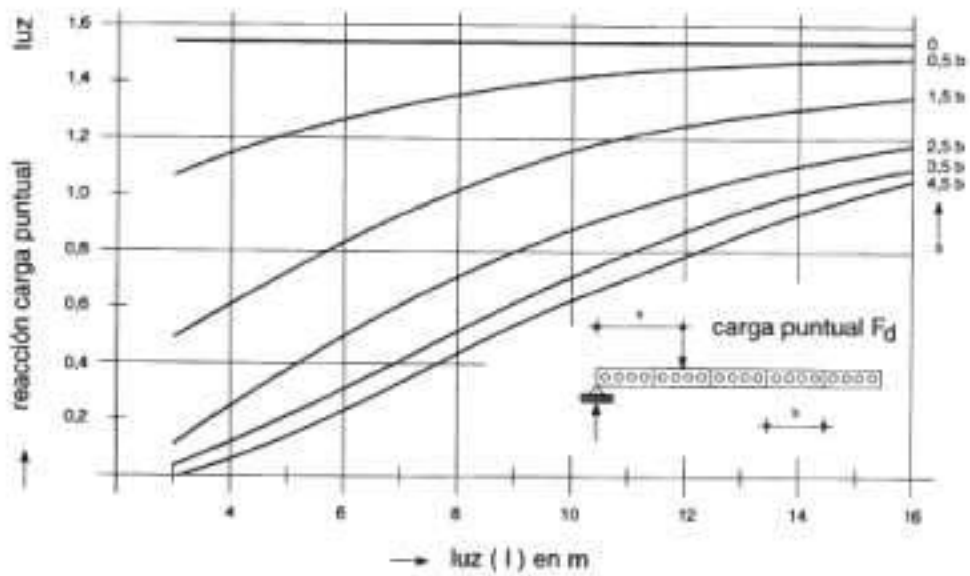

point load reaction
span

point load

span (l) in m

Figure A.12.5.2.5.b

Reaction force in the longitudinal support due to a point load in the centre of the span ($b=1,20$ m)

6 Special load and support cases

6.1 Transverse bending due to concentrated loads in prestressed hollow-core slabs

The action of concentrated loads causes transverse bending moments in prestressed hollow-core slabs. Given that these slabs do not have any transverse reinforcement, the tensile stresses due to these bending moments must be limited. The limit value depends on the basic calculation assumptions made with regard to the load distribution.

If the elements are designed without taking into account the transverse load distribution, which means that all the loads acting on an element would be withstood exclusively by that element, the limit value of the tensile stress is $f_{ct,k}$ in the Serviceability Limit State.

In this case, in the Serviceability Limit State, the capacity under concentrated loads, q_k , in N/mm, and under a point load, F_k , in N, is calculated as follows:

- a) for a linear load not situated at the slab edge:

$$q_k = \frac{20 W_{lb} f_{ct,k}}{\ell + 2b}$$

- b) for a linear load situated at the slab edge:

$$q_k = \frac{10 W_{lt} f_{ct,k}}{\ell + 2b}$$

where:

- l Length of the span, in mm.
b Width of the slab, in mm.

- c) for a point load situated anywhere in a slab area:

$$F_k = 3 W_l f_{ct,k}$$

where:

- W_l Smaller of the section moduli, W_{lb} and W_{lt} , in mm³/mm.

where:

- W_{lb} Minimum lower section modulus in the transverse direction per unit length, in mm³/mm.
 W_{lt} Minimum higher section modulus in the transverse direction per unit length, in mm³/mm.

If the prestressed hollow-core floor slabs are calculated taking into account the transverse load distribution according to the elasticity theory, which means that part of the loads acting on an element is distributed to the adjacent elements, the limit value of the tensile stress will be f_{ctd} in the Ultimate Limit State. The capacity to withstand concentrated loads, in this case in the Ultimate Limit State, may be determined using the same formulas but replacing q_k , F_k and $f_{ct,k}$ with q_d , F_d and $f_{ct,d}$, respectively.

6.2 Load capacity of prestressed hollow-core slabs supported on three edges

The action of loads distributed over a prestressed hollow-core slab with one supported longitudinal edge causes torsional moments in the slab. The reaction in the supports due to the torsion must be ignored in the Ultimate Limit State calculation.

The tangential stresses due to these torsional moments must be limited to $f_{ct,d}$ in the Serviceability Limit State.

The load capacity, q_k , per unit area, in N/mm, for the total load less the load due to the self-weight of the prestressed hollow-core slab will be calculated in the Serviceability Limit State as:

$$q_k = \frac{f_{ct,k} W_t}{0,06 \ell^2}$$

With $W_t = 2t(h - h_f)(b - b_w)$

where:

- W_t Torsional modulus of the section of an element according to the elasticity theory, in mm^3 ;
- t Smaller of the values of h_f and b_w , in mm.
- h_f Smaller value of the thickness of the upper or lower flange, in mm.
- b_w Thickness of the outer web, in mm.

7 Supports

7.1 Supports for joists floor slabs

Direct supports are those constructed when the ribs of a floor slab are connected to the tie chain of a wall or to a beam with a depth which is clearly greater than that of the floor slab. However, when connected to a flat joist, compound beam flange or header beam, these are known as indirect supports. Figures A.12.7.1.a to A.12.7.1.i show the usual support layouts for joists floor slabs of both types.

The lengths l_1 and l_2 indicated in the Figures are given, in general, by the expressions:

- a) for reinforced joists:

$$l_1 = \frac{V_d}{A_s f_{yd}} \cdot \ell_b \leq 100 \text{ mm} \quad l_2 = \frac{V_d - \frac{M_d}{0,9d}}{A_s f_{yd}} \cdot \ell_b \leq 50 \text{ mm}$$

where:

- h_o Minimum thickness of the site-cast top slab on the infill blocks, in mm.
- f_{yd} Design strength of the steel, in N/mm^2 .
- V_d Maximum design shear stress corresponding to a joist.
- A_s Area of the tension reinforcement actually used.
- M_d Design negative bending moment in continuous supports.
- d Effective depth of the floor slab.
- i_b Basic anchorage length of the bars of the positive moment reinforcement for the joist entering the support.

b) for prestressed joists:

$$l_1 = 100 \text{ mm} ; \quad l_2 = 60 \text{ mm}$$

In the cases shown in Figures A.12.7.1.c), A.12.7.1.f) and A.12.7.1.g), l_1 and l_2 correspond to the case of reinforced joists and the overlap lengths with the joist reinforcement in the end supports l'_1 and in the inner supports l'_2 will be equal to:

$$l'_1 = \frac{V_d}{p T_{rd}} \leq 100 \text{ mm} ; \quad l'_2 = \frac{V_d - \frac{M_d}{0,9d}}{p T_{rd}} \leq 60 \text{ mm}$$

where:

p Shear perimeter between joist and concrete in situ.

T_{rd} Design shear stress.

If, due to any error or deviation in execution, the beams or projecting reinforcements are short and do not comply with that indicated in the above cases, the solutions in Figures A.12.7.1.c), A.12.7.1.f) and A.12.7.1.g) shall respectively be applied.

a)

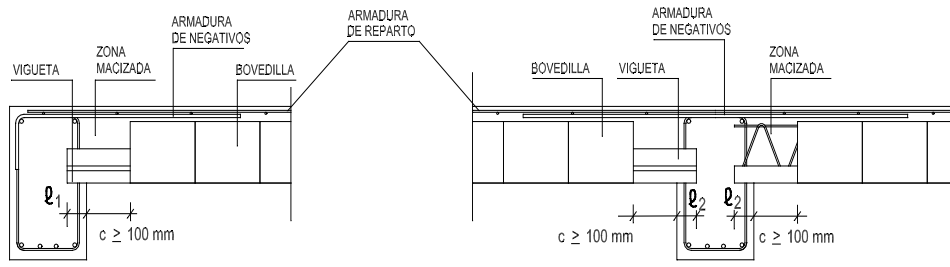

APOYO SENCILLO SOBRE VIGA DE CANTO
ENLACE POR ENTREGA

APOYO DOBLE SOBRE VIGA DE CANTO
ENLACE POR ENTREGA

b)

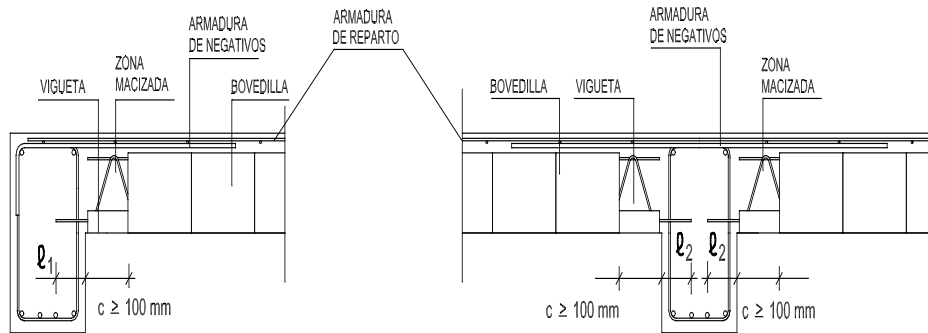

c)

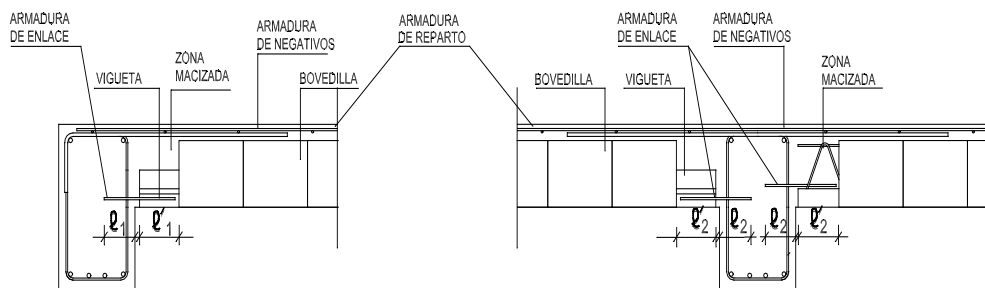

APOYO SENCILLO SOBRE VIGA DE CANTO
ENLACE POR SOLAPO

APOYO DOBLE SOBRE VIGA DE CANTO
ENLACE POR SOLAPO

d)

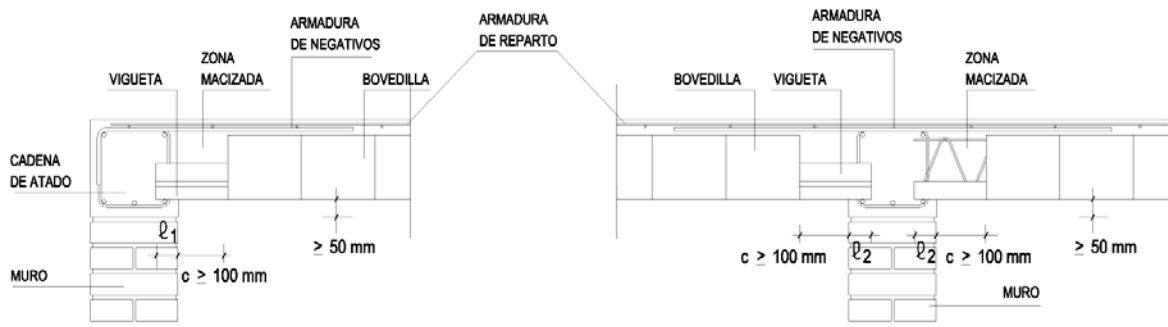

APOYO SENCILLO SOBRE MURO DE CARGA
ENLACE POR ENTREGA

APOYO DOBLE SOBRE MURO DE CARGA
ENLACE POR ENTREGA

e)

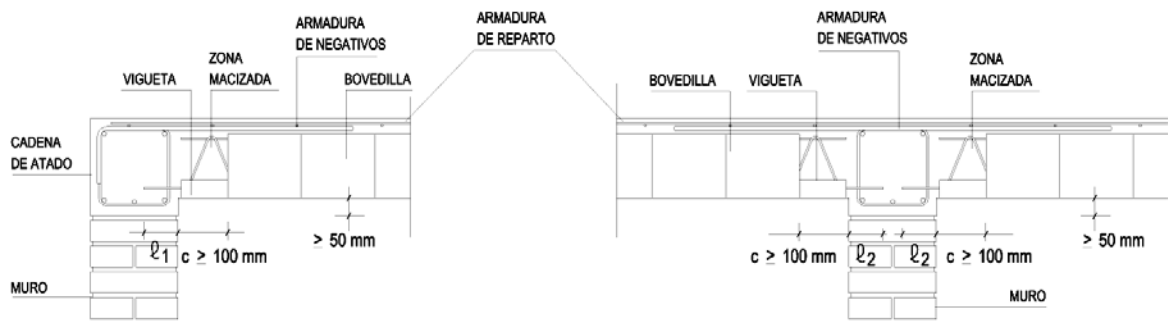

APOYO SENCILLO SOBRE MURO DE CARGA
ENLACE POR INTRODUCCIÓN DE ARMADURA SALIENTE

APOYO DOBLE SOBRE MURO DE CARGA
ENLACE POR INTRODUCCIÓN DE ARMADURA SALIENTE

f)

g)

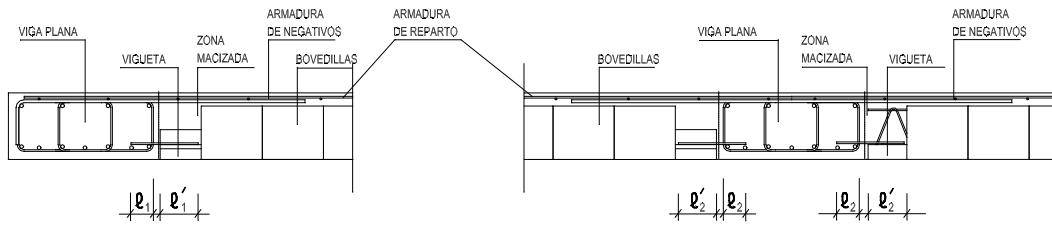

APOYO SENCILLO SOBRE VIGA PLANA
ENLACE POR SOLAPO

APOYO DOBLE SOBRE VIGA PLANA
ENLACE POR SOLAPO

h)

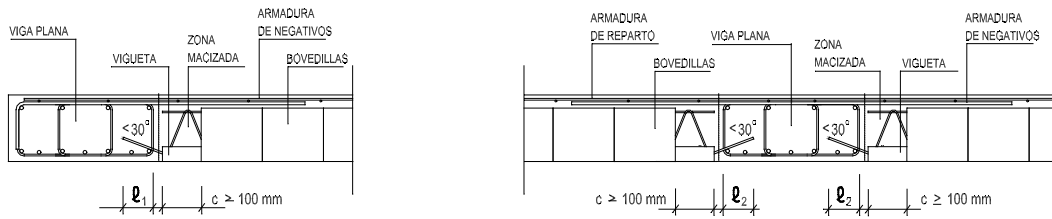

APOYO SENCILLO SOBRE VIGA PLANA
ENLACE POR INTRODUCCIÓN DE ARMADURA SALIENTE

APOYO DOBLE SOBRE VIGA PLANA
ENLACE POR INTRODUCCIÓN DE ARMADURA SALIENTE

i)

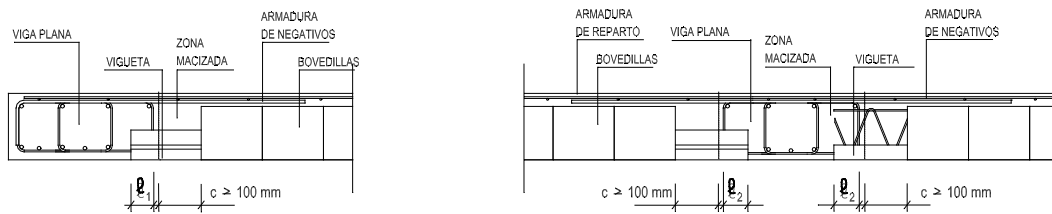

APOYO SENCILLO SOBRE VIGA PLANA
ENLACE POR ENTREGA

APOYO DOBLE SOBRE VIGA PLANA
ENLACE POR ENTREGA

j)

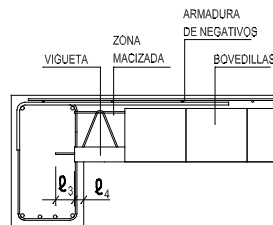

$$l_3 + l_4 \geq l_1$$

Figure A.12.7.1 Support details of beam floor slabs

a)
SINGLE SUPPORT ON EDGE BEAM
CONNECTED BY BEARING

DOUBLE SUPPORT ON EDGE BEAM
CONNECTED BY BEARING

b)
SINGLE SUPPORT ON EDGE BEAM
CONNECTED BY INTRODUCTION OF PROJECTING REINFORCEMENT

DOUBLE SUPPORT ON EDGE BEAM
CONNECTED BY INTRODUCTION OF PROJECTING REINFORCEMENT

c) [see original for diagram]

SINGLE SUPPORT ON EDGE BEAM
CONNECTED BY OVERLAP

DOUBLE SUPPORT ON EDGE BEAM
CONNECTED BY OVERLAP

[key to diagrams a), b) and c)]

VIGUETA = BEAM

ZONA MACIZADA = INFILLED ZONE

ARMADURA DE NEGATIVOS = NEGATIVE REINFORCEMENT

BOVEDILLA = FLOORING BLOCK

ARMADURA DE REPARTO = INTERMEDIATE REINFORCEMENT

ARMADURA DE ENLACE = CONNECTING REINFORCEMENT

d) [see original for diagram]

SINGLE SUPPORT ON BEARING WALL
CONNECTED BY BEARING

DOUBLE SUPPORT ON BEARING WALL
CONNECTED BY BEARING

e) [see original for diagram]

SINGLE SUPPORT ON BEARING WALL
CONNECTED BY INTRODUCTION OF PROJECTING REINFORCEMENT

DOUBLE SUPPORT ON BEARING WALL
CONNECTED BY INTRODUCTION OF PROJECTING REINFORCEMENT

f) [see original for diagram]

SINGLE SUPPORT ON BEARING WALL
CONNECTED BY OVERLAP

DOUBLE SUPPORT ON BEARING WALL
CONNECTED BY OVERLAP

[key to diagrams d), e) and f)]

CADENA DE ATADO = TIE CHAIN

MURO = WALL

VIGUETA = BEAM
ZONA MACIZADA = INFILLED ZONE
ARMADURA DE NEGATIVOS = NEGATIVE REINFORCEMENT
BOVEDILLA = FLOORING BLOCK
ARMADURA DE REPARTO = INTERMEDIATE REINFORCEMENT
ARMADURA DE ENLACE = CONNECTING REINFORCEMENT

g) [see original for diagram]

SINGLE SUPPORT ON FLAT BEAM
CONNECTED BY OVERLAP

DOUBLE SUPPORT ON FLAT BEAM
CONNECTED BY OVERLAP

h) [see original for diagram]

SINGLE SUPPORT ON FLAT BEAM
CONNECTED BY INTRODUCTION OF PROJECTING REINFORCEMENT

DOUBLE SUPPORT ON FLAT BEAM
CONNECTED BY INTRODUCTION OF PROJECTING REINFORCEMENT

i) [see original for diagram]

SINGLE SUPPORT ON FLAT BEAM
CONNECTED BY BEARING

DOUBLE SUPPORT ON FLAT BEAM
CONNECTED BY BEARING

j) [see original for diagram]

[key to diagrams g), h), i) and j)]

VIGA PLANA = FLAT BEAM
VIGUETA = BEAM
ZONA MACIZADA = INFILLED ZONE
ARMADURA DE NEGATIVOS = NEGATIVE REINFORCEMENT
BOVEDILLAS = FLOORING BLOCKS
ARMADURA DE REPARTO = INTERMEDIATE REINFORCEMENT

7.2 Supports for prestressed hollow-core slabs

7.2.1 Direct supports

In the case of direct support, the nominal minimum bearing, l_1 , measured from the edge of the prestressed hollow-core slab to the inner edge of the actual support, shall be fixed according to the following criteria:

- a) If all the following conditions are simultaneously met:
- the design loads are distributed and there are no significant point loads or major horizontal loads, including seismic loads,
 - the overload is equal to or less than 4 kN/m^2 ,
 - the depth of the hollow-core slab is equal to or less than 30 cm, and
 - the design shear V_d is less than half that withstood by the prestressed hollow-core slab V_{u2} according to Article 44.2.3.2

$$V_d \leq V_{u2} / 2$$

The nominal minimum bearing l_1 will be 50 mm, on which a tolerance of -10 mm is permitted so that the actual bearing in situ will never be less than 40 mm;

- b) If any of the above conditions are not met, the minimum value of l_1 must also be determined by checking that, in the inner edge section of the support, the lower active reinforcement, taking into account its parabolic anchorage, is capable of anchoring the design shear V_d . If the anchorage capacity of the active reinforcement is not sufficient, this reinforcement could be supplemented by passive reinforcement, correctly anchored, placed in the longitudinal joints between adjacent slabs or in infilled hollow cores, and overlapped with the active reinforcement of the slab.

When the support is constructed on mortar, it shall be considered that this material is rigid under horizontal actions and that its coefficient of friction is similar to that of concrete. Also, if the geometry of the direct support (geometry of the floor slab in relation to the geometry of the element supporting this) presents any opposition to horizontal movement, mortar cannot improve this situation and has no capacity to recentre the load in the event of successive horizontal movements in the opposite direction, which is why displacements may accumulate to the prejudice of the minimum bearing, l , required.

The same condition must be met when placing the inner edge of the elastomeric support in relation to said corner, or face, of the element supporting the floor slab.

7.2.2 Indirect supports

Indirect supports may be constructed with or without shoring of the prestressed hollow-core slab. Figures A.12.7.2 a) and b) show indirect supports with and without shoring.

- without shoring of the prestressed hollow-core slab supported on the beam or wall with connecting reinforcement (Figure A.12.7.2 b). The minimum nominal value of l_1 will be 40 mm, on which a tolerance will be accepted, including that of the length of the prestressed hollow-core slab, of ± 10 mm such that the actual bearings in situ are no less than 30 mm.
- with shoring of the prestressed hollow-core slab (Figure A.12.7.2 a).

ARMADURAS ALOJADAS EN LAS JUNTAS O EN LOS ALVEOLOS, MEDIANTE CORTE LOCAL EN LA LOSA SUPERIOR DE LA PLACA SOBRE EL ALVEOLO

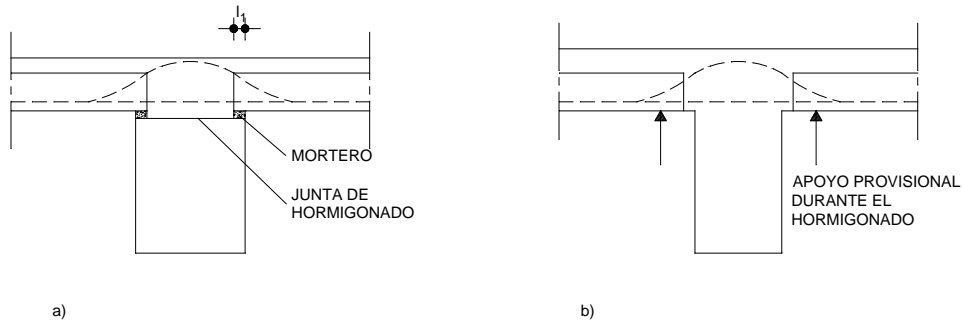

REINFORCEMENTS PLACED AT THE JOINTS OR IN THE HOLLOW CORES BY LOCALLY CUTTING, IN THE TOP SLAB, THE PLATE ABOVE THE HOLLOW CORE

[see original for diagram]

[see original for diagram]

MORTAR
CONCRETING JOINT

TEMPORARY SUPPORT DURING CONCRETING

Figures A.12.7.2. a) and b) Indirect supports for hollow-core slabs: a) without shoring of the prestressed hollow-core slab, b) with shoring of the prestressed hollow-core slab

Indirect supports require specific checks and must be calculated in accordance with the criteria in this Code or the specific standards for these products.

In general, except in special cases and whatever the type of support, it will be necessary to concrete, across the whole depth of the floor slab, the joints where the ends of the slabs meet the opposite slabs, trusses or walls. In addition, passive reinforcement must be inserted which shall be longitudinal to the slabs, which shall cross the joint and which shall be anchored on both sides.

In this case, and to ensure correct concreting of the joints and, where applicable, infilling of the hollow cores, plugging elements must be placed in the hollow cores, made of plastic or similar, which guarantee that the dimensions of the joints or infill comply with those specified in the design.

Reinforcements may be placed in the site-cast top slab or at the longitudinal joints between slabs if the joint and reinforcement dimensions allow correct concreting of this, or in infilled hollow cores, after breaking the roof of these at a certain length. If this solution is chosen, at least one hollow core will be infilled in each prestressed hollow-core slab with a width equal to or less than 60 cm and two in wider slabs.

8 Connections

8.1 Alignment of ribs

When the continuity of floor slabs is taken into account, the ribs or beams shall be aligned. However, a deviation less than the straight distance between faces in inner supports and up to 5 cm in overhanging supports may be permitted (Figure A.12.8.1.a).

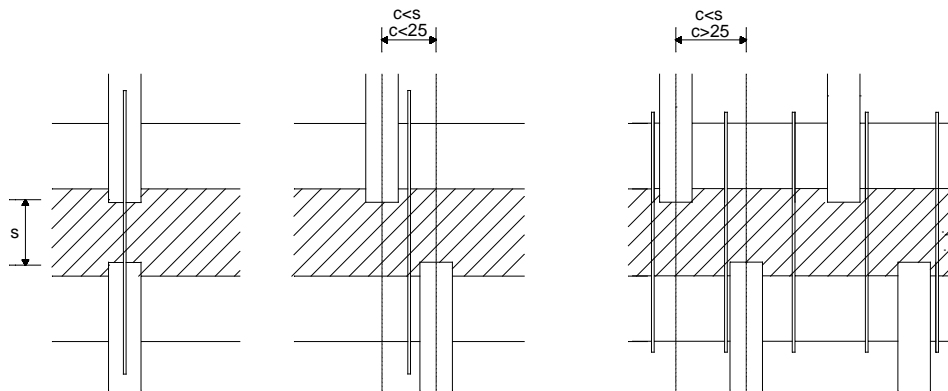

Figure A.12.8.1.a Alignment of ribs

In cases where a floor slab meets another perpendicularly, its upper reinforcement shall be anchored via a straight extension (Figure A.12.8.1.b). When an overhang has ribs perpendicular to those in the adjacent section, its upper reinforcement shall be anchored via a straight extension with a length not less than the length of the overhang or twice the inter-axis. Mention should be made of the importance, in cases of floor slabs perpendicularly overhanging the adjacent span, of the calculation to determine the length of the infill and the loads on the beam perpendicular to the overhang, particularly if the loads acting on this are higher than those on the span of the adjacent floor slab.

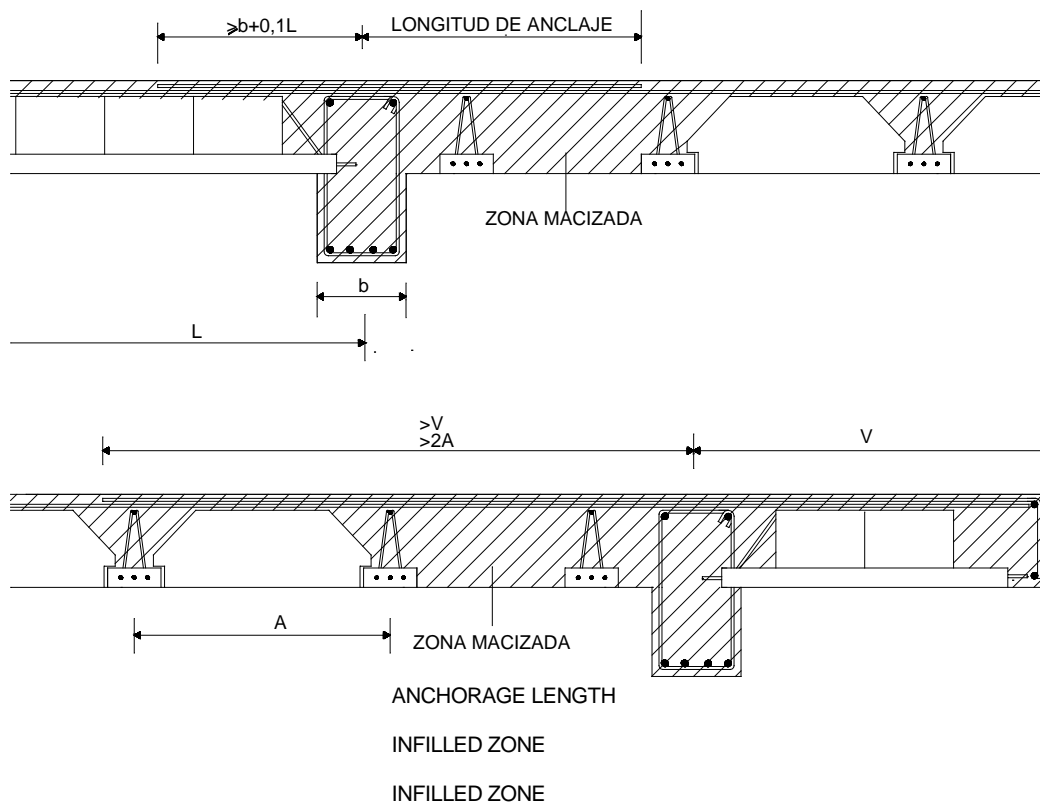

Figure A.12.8.1.b Meeting point between perpendicular floor slabs

In both cases, the compressive strength of the lower part of the floor slab shall be guaranteed by infilling the necessary parts or using equivalent measures (Figure A.12.8.1.b).

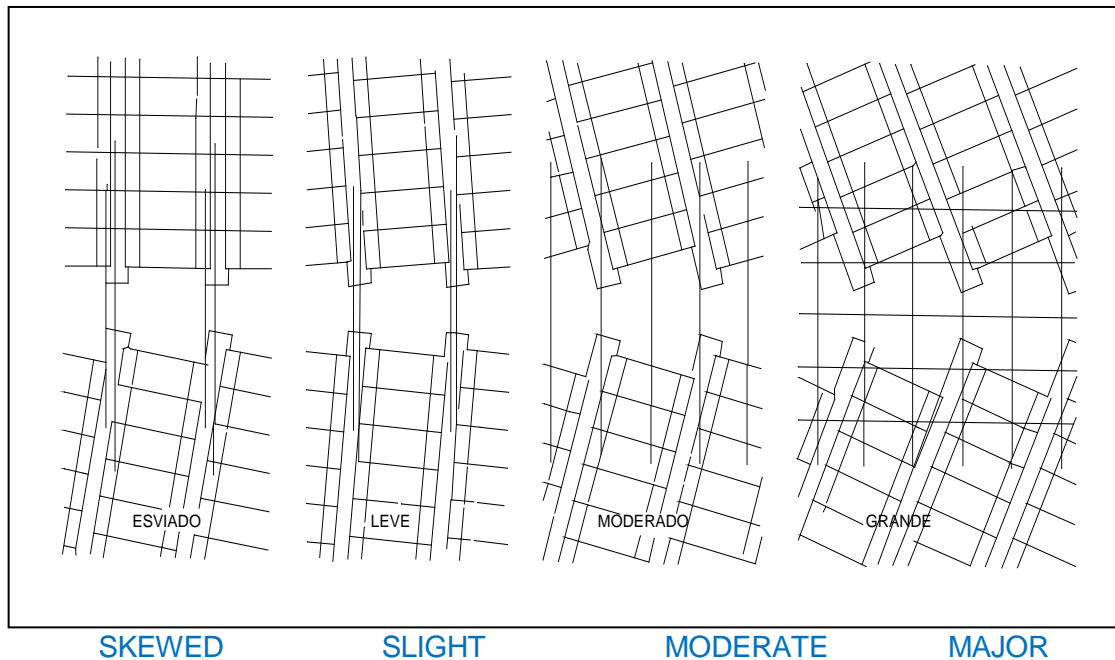

Figure A.12.8.1.c Oblique meeting point between beams

If the joists meet the support obliquely, for small angles, for example less than 22° , the calculated reinforcement (bearing in mind that efficiency is lost with the cosine to the square of the angle) may be placed according to the bisector of both directions. If the angle is larger, it is advisable to insert a grid whose section, in either of the two directions, is equal to that theoretically needed (Figure A.12.8.1.c).

Any deviation c causes stresses which are superimposed on those of the beam. These may be important if the above limits are exceeded. If the deviation c is less than 25 cm, the upper reinforcement may be placed on each pair of beams aligned at the supports, but always respecting the minimum covers specified in this Code. In the case where c is greater than 25 cm, the reinforcement will be distributed along the support line.

9 Unwanted constraints in prestressed hollow-core slabs. Minimum reinforcement at single supports

9.1 General

When calculating prestressed hollow-core slabs and when detailing their joints at supports, the unwanted constraints and their implicit negative moments must be taken into account in order to avoid possible cracking caused by the constraint on rotation which could initiate a shear failure in the vicinity of the support.

The following methods may be used to take account of the negative moments due to unwanted constraints:

- a) Design the joint so that these moments are not produced.
- b) Design and calculate the joint so that the cracks which may be produced do not result in dangerous situations.
- c) Take into account in the calculation the negative moments due to the unwanted constraints. This procedure is detailed below.

9.2 Design by means of calculation

The following calculation procedure may be adopted:

- a) At the ends of the supports, which are assumed to be free supports, unless adjustment moments cannot develop due to the nature of the support, a negative bending moment must be taken into account in the support equal to the smaller of the following values:

$$M_{d,f} = \frac{M_{1d}}{3}$$

$$M_{d,f} = \frac{2}{3} N_{d,sup} a + \Delta M$$

with ΔM equal to the higher of:

$$\Delta M = f_{ct,d} W \quad \text{and} \quad \Delta M = f_{yd} A_{std} + \mu_b N_{d,sup} h$$

If the distance between the extreme edges of the hollow-core slabs is less than 50 mm or if the joint is not filled, then ΔM will be taken as equal to the smaller of the following values:

$$\Delta M = \mu_b N_{d,sup} h \quad \text{and} \quad \Delta M = \mu_o N_{d,inf} h$$

where (see also Figure A.12.9.2):

- M_{1d} Maximum design moment in the span, equal to $\gamma_G (M_G - M_{pp}) + \gamma_Q M_Q$ with:
 M_G Characteristic maximum moment in the span due to permanent actions.
 M_Q Characteristic maximum moment in the span due to variable actions.
 M_{pp} Characteristic maximum moment in the span due to the self-weight of the floor slab.
- a Length of the support as shown in the Figure.
 A_s Cross-sectional area of the connecting reinforcement.
 D Distance from the lower fibre of the slab to the position of the connecting reinforcement.
 h Depth of the slab.
 f_{yd} Design strength of the steel.
 $N_{d,sup}$ Design value of the total normal stress in the upper face of the floor slab.
 $N_{d,inf}$ Design value of the total normal stress in the lower face of the floor slab.
 W Section modulus of the site-cast concrete section between the ends of the elements.
 μ_o Coefficient of friction in the lower side of the slab.
 μ_b Coefficient of friction in the upper side of the slab.
 μ_o and μ_b taken as:

- 0,80 For concrete on concrete.
- 0,60 For concrete on mortar.
- 0,25 For concrete on rubber or neoprene.
- 0,15 For concrete on fibre felt.

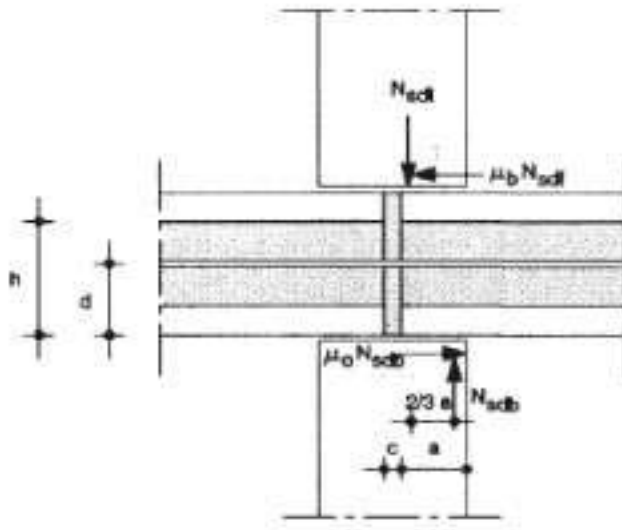

Figure A.12.9.2 Unwanted moments due to impeded deformation

- b) No reinforcement is needed to absorb the moments due to the constraint on rotation if the following is met:

$$M_{d,f} \leq 0,5 (1,6 - h) f_{ct,d} W_t$$

where:

h Depth of the slab, in m.

W_t Section modulus of the slab with regard to the upper fibre.

If the above condition is not met, the negative moments determined, $M_{d,f}$, must be withstood: at the joint between opposite slabs, by passive reinforcement placed in the site-cast top slab or, if this does not exist, in the longitudinal joint between adjacent slabs or in infilled hollow cores; in the prestressed hollow-core slab sections, the effect of the prestressing transfer force developed by the upper wire rods or strands may be taken into account.

If, in the section situated at mid-depth from the free edge of the support, the effect of the negative moment, $M_{d,f}$, plus the prestressing developed as established in Article 44 causes tensions higher than $f_{ct,d}$ in the upper fibre of the prestressed hollow-core slab, in addition to the check involving positive moments and lower reinforcements according to that Article, another additional check shall be made, for this section, according to Article 44.2.3.2.1.b), involving a negative moment and upper reinforcement.