

# Experimental results of gain fluctuations and noise in microwave low-noise cryogenic amplifiers

Juan Daniel Gallego\*, Isaac López-Fernández, Carmen Diez, Alberto Barcia

Centro Astronómico de Yebes, Observatorio Astronómico Nacional,  
Apartado 148, 19080 Guadalajara, SPAIN.

## ABSTRACT

Applications like radio astronomy and space communications require ultimate sensitivity and make use of very particular receivers with state-of-the-art devices. Usually the receivers are cooled at cryogenic temperatures to reduce the noise even further. Noise temperatures of only a few times the quantum limit can be obtained in these conditions. During the past decade, Indium Phosphide HEMTs have demonstrated the best noise performance at cryogenic temperatures in the microwave frequency range of all active semiconductor devices, together with extremely low power consumption. For certain applications noise is not the only factor affecting the sensitivity. For example, gain fluctuations may play a dominant role in wide band radiometers. Unfortunately some of the factors that have contributed to improve the noise temperature have degraded the gain fluctuations. The operation at cryogenic temperatures also increases the fluctuations. This paper describes the experimental results obtained at the Centro Astronómico de Yebes (CAY) in the development of wide band cryogenic amplifiers. Special attention is paid to the influence of the bias point in noise and gain fluctuations. InP HEMTs from different foundries were tested. The amplifiers developed will be used in the Herschel ESA mission radiometers and the Atacama Large Millimeter Array (ALMA) receivers.

**Keywords:** Cryogenic Amplifier, low noise, InP, gain fluctuations, sub-millimeter radiometers.

## 1. INTRODUCTION

There are some important applications requiring ultimate sensitivity at microwave frequencies, no matter the cost. Some of them are Radio Astronomy, Deep Space communications, SETI (Search for Extra Terrestrial Intelligence), and Nuclear Science. Cryogenic low noise microwave receivers with outstanding performance have been used since the 60's. Masers cooled to Liquid Helium temperature developed in the 60's obtained impressive noise temperatures, beating sensitivity records during many years. A lower cost alternative for the masers were the cooled parametric amplifiers, requiring less complex cryogenics and providing more affordable microwave receivers. Masers and parametric amplifiers were excellent for noise, but the receivers obtained a limited instantaneous bandwidth. During the 70's the new Schottky gate GaAs FET microwave transistor emerged as an alternative and the first cryogenic amplifiers using three terminal devices were successfully developed and implemented. In the 80's, the GaAs FET evolved into HEMTs using semiconductor heterostructures, improving noise figure and maximum frequency of operation. In the 90's the performance was improved even further using InP as the base material for the heterostructures. The simultaneous evolution of microlithography reduced the gate width from 1 to less than 0.1 micron over the years. The parallel combined effect of new semiconductor materials and modern microlithography has produced devices with outstanding cryogenic performance in the microwave frequency range. Nowadays cryogenic HEMT amplifiers with very wide instantaneous bandwidth are regularly used for the first stage in receivers up to about 100 GHz (Webber<sup>3</sup>, Pospieszalski<sup>4</sup>), and for IF amplifiers in heterodyne receivers at higher frequency (López-Fernández<sup>5,6</sup>).

Applications like Radio Astronomy and radiometry have been demanding wider instantaneous bandwidth for the amplifiers, to improve spectral coverage and sensitivity. With the increase of bandwidth and the reduction of noise temperature, other factor limiting the sensitivity began to play an important role: the gain fluctuation. It is upsetting that

---

\* [jd.gallego@oan.es](mailto:jd.gallego@oan.es); phone +34 949 290311; fax +34 949 290063; <http://www.oan.es>; Centro Astronómico de Yebes, Observatorio Astronómico Nacional, Apartado 148, 19080 Guadalajara, SPAIN.

every step taken to improve the noise performance of microwave transistors has contributed to degrade their gain fluctuation. In general, the gain fluctuation is larger in amplifiers at cryogenic than at ambient temperature. Besides, HEMT devices perform worst and it is even worst if they are based in InP. The gain fluctuation is increased with the reduction of gate area, so shorter gate devices show more fluctuation. The combination of all this factors makes cryogenic InP amplifiers an excellent choice for low noise and wide bandwidth, but not very good for gain fluctuation.

The problem of gain fluctuation in radiometer receivers has been long known, and some configuration like Dike switching or correlation receivers have been used to deal with it. But still, the fluctuations in the gain of cryogenic amplifiers are an important factor in determining the overall sensitivity of the system and should be well characterized. For this reason, modern state of the art instruments using cryogenic amplifiers have a specification for the gain fluctuation. This is for example the case of HIFI instrument of Herschel ESA mission or ALMA. The aim of this work is to present the measurement techniques used and the experimental results obtained in a number of low noise cryogenic amplifiers.

This paper presents the experimental results of noise and gain fluctuations obtained in InP cryogenic amplifiers developed for HIFI instrument of Herschel<sup>1</sup> and for ALMA<sup>2</sup>. Section 2 describes the measurement systems. Note that the measurement instruments used are standard, but used in a peculiar way. Section 3 presents the measurements. The influence of the measurement temperature, the device technology, the frequency band and the illumination is analyzed. Special attention is paid to the bias conditions. Some statements of certain statistical significance are inferred from the performance of long series of amplifiers. Finally, the conclusions of this work are displayed.

## 2. MEASUREMENT TECHNIQUES

### 2.1. Noise measurement

Accurate measurement of the low noise temperature of cryogenic amplifiers is a challenge. Measurements of the same device taken by different laboratories may be quite different (Wadefalk<sup>7</sup>). Cryogenic amplifiers should be operated inside a cryostat and are connected by transition lines. Measurements inside a cryostat with noise sources connected outside are almost useless, because the effect of the input connecting transition is very difficult to de-embed and its contribution to the total noise of the system is often larger than the noise temperature of the amplifier.

Several methods based on the use of more adequate noise references have been conceived to improve the accuracy. Switched cryogenic loads (Pan<sup>9</sup>), variable temperature cryogenic loads (McGrath<sup>10</sup>) and diode noise sources with cryogenic attenuators (Gallego<sup>8</sup>) are described in the literature. The goal of the three methods is to make the measurements less sensitive to the dewar transitions or even to avoid them. Very good absolute accuracy can be obtained using two different cryogenic loads, but only in the case of devices insensitive to changes in the input impedance (as in the case of room temperature noise measurements). With a variable temperature load, devices sensitive to input impedance variations can be measured with good accuracy and the calibration is based on measurements of the physical temperature of the load. However, this method is very time consuming, and not adequate for swept measurements. The method of the noise source with the cryogenic attenuator is also adequate for devices sensitive to the input impedance and it is the most convenient for swept measurements with a commercial noise figure meter. As the realization of swept measurements was considered fundamental for routine tests of cryogenic amplifiers, the cold attenuator method was chosen in our laboratory. With this, the repeatability of the measurements ( $f \approx 8$  GHz) is about  $\pm 0.2$  K. The absolute accuracy is more complex to estimate (Gallego<sup>8</sup>, HP<sup>11</sup>), but it is approximately  $\pm 1.4$  K, and it is dominated by the calibration of the cryogenic thermometer used to sense temperature of the attenuator.

Figure 1 presents the block diagram of the cold attenuator measurement set up. The noise diode is located outside the cryostat, and there is a DC-block and an attenuator inside. The function of the DC block is not to isolate the inner conductor of the coaxial lines for DC, but to reduce the heat arriving to the attenuator through the coaxial line. If a DC block or other type of thermal isolation is not included, the inner part of the attenuator can be hotter than its body, and the temperature sensed is not correct. This effect gives noise measurements too pessimistic. The value chosen for the attenuator is a compromise. Should be low enough to obtain an appreciable difference of noise between on and off, and

high enough to make the contribution of the losses in the transition lines negligible, and to obtain a equivalent noise temperature in off state close to the physical temperature of the attenuator.

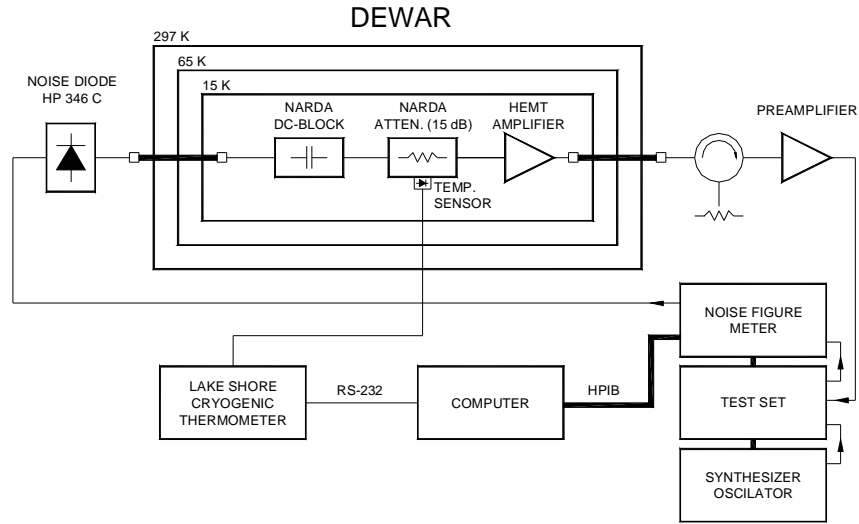

**Figure 1** Block diagram of cryogenic noise measurements with the cold attenuator method.

Calibration tables are stored in a computer with values of the ENR of the noise source and losses of the lines and attenuator. The equivalent temperature presented to the amplifier with the noise source off and on is calculated for each frequency based on the data of the tables and the actual cryogenic temperature. The cold (off) temperature is calculated taking into account the contributions of the input lines (supporting the temperature gradient) and the DC-block and attenuator. For the input lines, a linear temperature distribution can be assumed. Then, the equivalent temperature at the end of the line is (Stelzried<sup>12,13</sup>)

$$T_{e2} = \frac{T_{e1}}{L} + \left(1 - \frac{1}{L}\right) \cdot T_2 - \left(\frac{1}{L} - \frac{1}{L'}\right) \cdot T_1, \quad (1)$$

where  $T_{e1}$  is the equivalent temperature at the input of the line,  $L$  is the total loss and  $T_1$  and  $T_2$  the physical temperatures at each end.  $L'$  can be calculated as

$$L' = \frac{10 \cdot \log_{10}(L)}{10 \cdot \log_{10}(e)} = \frac{L \cdot [dB]}{10 \cdot \log_{10}(e)} \cong 0.23036 \cdot L \cdot [dB]. \quad (2)$$

In the case of a line at uniform temperature, or for an attenuator, the equivalent temperature at the output is

$$T_{e2} = \frac{T_{e1}}{L} + \left[1 - \frac{1}{L}\right] \cdot T, \quad (3)$$

where  $T$  is the physical temperature and the meaning of the other symbols is the same as in (1). The value of the cold temperature at the input port of the amplifier can be obtained chaining the results of (1) and (3). Finally, the equivalent hot temperature (noise source on) can be obtained from the Excess Noise Ratio,

$$ENR(dB) = 10 \cdot \log_{10} \frac{T_{on} - T_{off}}{290 \cdot K}, \quad (4)$$

where  $T_{on}$  and  $T_{off}$  are the equivalent temperatures at the output of the attenuator with the noise source on and off. The ENR can be calibrated using a receiver and loads at ambient and LN<sub>2</sub> temperature as in Gallego<sup>8</sup> or calculated subtracting the total insertion loss of the lines and the attenuator from the ENR of the diode noise source given by the manufacturer. In our experience, if the losses are carefully measured, the value obtained by calculation is better, since our equipment is not the most adequate for calibration with ambient and LN<sub>2</sub> loads (drift, reflections...). The values of  $T_{off}$  and  $T_{on}$  at 8 GHz in our system are typically ~20 and ~200 K. If all the losses are considered concentrated in the attenuator, these values change only ~0.15 K.

The error in the noise temperature and gain measurements obtained with the cold attenuator measurements can be estimated using a Monte Carlo simulation of the measurements as described in Gallego<sup>8</sup>. The results of our system for a cryogenic amplifier ( $T_n=4$  K  $G=30$  dB) appear in Table 1. The main source of error is the calibration of the diode temperature sensor used to measure the temperature of the attenuator. The precision of this sensor is  $\pm 1$  K, and this causes an error of the same magnitude in the noise temperature measured. The next factor in importance is the calibration of the noise diode and the losses in the attenuator. The table also presents the total contribution of all the other error sources like reflection effects, second stage contribution, gain variations and fluctuations due to finite integration time. The error in the gain measured with this method is obtained the simulation too, and it is  $\pm 0.7$  dB. For comparison, the error in noise temperature measurements for an amplifier at room temperature ( $T_{amb}=297$  K) of  $T_n=90$  K and  $G=30$  dB, measured with the HP 346 A noise diode is  $\pm 13$  K.

SOURCE OF ERROR	CONTRIBUTION
Calibration of Noise Source	0.77 K
Calibration of cold attenuator	0.54 K
Calibration of temperature sensor	1.00 K
All other	0.34 K
<b>TOTAL</b>	<b>1.40 K</b>

**Table 1** Example of error budgets for noise measurements with the cold attenuator method (8 GHz).

## 2.2. Gain fluctuations measurement

Two different measurements have been proposed to characterize gain fluctuations: The Allan variance (Allan<sup>14</sup>, Kooi<sup>15</sup>) and the spectrum of normalized gain fluctuation (Wollack<sup>16</sup>, Seifert<sup>18</sup>). As both provide similar information, only the second one is used in this work. Gain fluctuations of cryogenic amplifiers are low but measurable. As they are quite important for radiometers, most of the results reported previously in the literature (Wollack<sup>16</sup>, Jarosik<sup>17</sup>) were deduced from measurements of total power at the output of wide band receivers with thermal noise sources at the input. In this case, the total fluctuation appearing in the measured power is due to: 1) fluctuation of the gain and 2) random nature of the input signal. The contribution 2) is inversely proportional to the square root of the pre-detection bandwidth and the measured power shows a white noise spectrum due to it. On the other hand, the contribution 1) shows typically a  $1/f^\alpha$  spectrum, and its value does not depend on the pre-detection bandwidth. For this reason, the effect of gain fluctuation dominates for very wide band instruments.

The set up used in this work for measuring gain fluctuation was conceived using a CW signal at the input instead of wide band random noise (Gallego<sup>19</sup>). In this sense, the fluctuations measured are expected to mimic the effect in one channel of a spectral line receiver of the type used in radio astronomy. Unfortunately, our system does not provide information on the simultaneous effect at other frequencies in the band pass of the amplifier. Additional work is needed to clarify whether the fluctuations are simultaneous in the pass band or not. The aim of the method was to perform routine gain stability tests over cryogenic amplifiers using standard microwave equipment readily available in our laboratory. The measurements have been made injecting a stable CW signal from a HP 83650 B synthesizer and detecting the output power in a narrow band tuned to the carrier frequency in the receiver of a HP 8510 C Vector Network Analyzer. The level of the signal was adjusted using a continuously variable attenuator at the input of the amplifier to obtain a power level of -20 dBm at the output. This level is selected to avoid compression. The measurement obtained is a combination of the fluctuations of the measurement system and the amplifier. The fluctuations of the measurement system limit the sensitivity of the measurement, and should be of lower level than those

of the amplifier to obtain significant data. The measurement of an amplifier is finally obtained discounting the fluctuations due only to the measuring system. To do this is necessary to calibrate the system, taking data without amplifier, adjusting the variable attenuator to measure the same signal level at the receiver.

The measurements of the spectral density of normalized gain fluctuations are obtained by Fast Fourier Transform of time domain data acquired with the HP8510 C Vector Network Analyzer. Several spectrums (typically 50) are averaged to reduce the random fluctuations. The sweeping time and number of points are selected to obtain spectrums in the 0.012-2.34 Hz range. The calibration of the measurements is done by discounting the contribution of the system in the frequency domain. The final spectrum obtained for a cryogenic amplifier is usually of the form:

$$S(f) = b \cdot \left( \frac{1 \cdot \text{Hz}}{f} \right)^\alpha \quad (5)$$

The exponent  $\alpha$  is normally close to 0.5 and the value of  $b$  is the parameter used to compare different devices or amplifiers.  $b$  is known as the value of the spectral density of normalized gain fluctuations at 1 Hz, and its units are  $1/\sqrt{\text{Hz}}$ . Typical values of  $b$  for InP amplifiers are  $\sim 10^{-4} 1/\sqrt{\text{Hz}}$ , but are very dependant of the type of devices used. Figure 2 presents an example of a measurement of gain fluctuations of a cryogenic amplifier. A picture of the measurement system is shown in Figure 3.

### 3. DATA AND RESULTS

#### 3.1. Device technology, ambient temperature and effects of other variables in noise and gain fluctuations

In section 1 it was stated that InP devices at cryogenic temperatures were a very good choice for low cryogenic noise, but not so for small gain fluctuations. In the early stages of the introduction of InP technology in IF amplifiers, we performed some tests to validate its feasibility (the higher cut-off frequency seemed a risk for the stability at lower frequencies) and possible drawbacks, comparing three prototype Herschel amplifiers designed for the 8 – 12 GHz band, each of them with a different first stage transistor. Some of the results of those tests are summarized in Table 2.

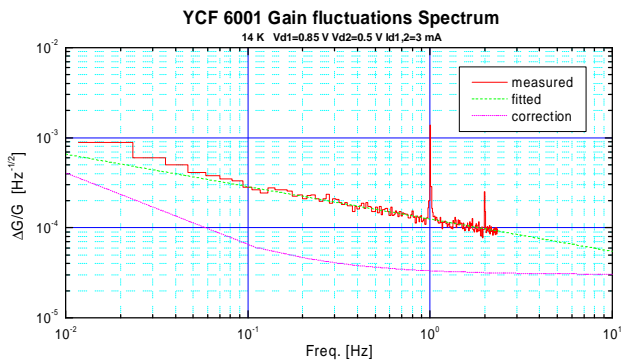

**Figure 2** Example of calibrated measurement of the Spectral Density of Normalized Gain Fluctuations of amplifier YCF 6001. The measured data presented has been corrected to eliminate the contribution of system fluctuations. The value of the correction is also shown in the graph as a reference. The peak appearing at 1 Hz is due to the cycle of CTI 1020 refrigerator. A smaller peak at 2 Hz is also visible.



**Figure 3** Low noise amplifier in the cryostat for gain fluctuation measurements.

DEVICES		NOISE TEMPERATURE [K]			GAIN FLUCTUATIONS [ $\text{Hz}^{-1/2}$ ]		
TECHNOLOGY	MODEL	297 K	14 K	VARIATION	297 K	14 K	VARIATION
GaAs	FHX13X 200×0.25 $\mu\text{m}$	99	13.6	÷ 7.3	2.0E-5	3.4E-5	× 1.7
InP	NGST 160 160×0.1 $\mu\text{m}$	96	6.5	÷ 14.8	(1.3E-5)	9.4E-5	× (7.2)
	ETH 200 <sup>†</sup> 200×0.2 $\mu\text{m}$	108	6.7	÷ 16.1	(1.0E-5)	7.0E-5	× (7.0)
GaAs – InP Variation [times]		None	÷ 2.1	–	÷ (1.7)	× 2.8	–

**Table 2** Comparison of the noise temperature and gain fluctuations performance of 1<sup>st</sup> stage InP and GaAs devices in a 2-stages 8-12 GHz LNA (YXF 1) measured at cryogenic and room temperatures. GaAs – InP comparison uses data of NGST 160 device. Gain fluctuations at room temperature data enclosed in parenthesis are only estimations, since the result is below the system noise.

Gain fluctuations data correspond to the device of the first stage and are represented by the spectral density of the normalized gain fluctuations at 1 Hz (b). The spectra were taken at 10 GHz. The contribution of the second stage has been extracted from the amplifiers measurements assuming identical contribution of all the Fujitsu<sup>‡</sup> FHX13X devices involved (note that all amplifiers have a Fujitsu transistor in the second stage). Average noise temperature in the band is dominated by the first stage device. The performance of the InP devices is similar: there is a very important improvement of the noise temperature when cooling the device (around 15 times) and a degradation of almost an order of magnitude (7 times) of the gain fluctuations. The GaAs device has similar noise at room temperature, but the improvement after the cool-down is only half the InP devices. However, GaAs gain fluctuations at cryogenic temperatures are almost 3 times better than the InP results, because the diminishment after cool-down is only of 1.7 times. So the behavior for both technologies is similar at room temperature but better in noise for InP and in gain fluctuations respectively for GaAs when cooling. Figure 4 shows an example of fluctuations spectra of amplifiers with InP and GaAs devices at room and cryogenic temperatures.

Another variable that affected the performance of HEMT devices at cryogenic temperatures was the illumination. The early HEMTs needed to be illuminated (usually by LEDs) to work properly when cooled. The effect of the illumination in the noise performance of modern devices is either unnoticeable or marginally negative. We report measurements of gain fluctuations for illuminated devices; in all cases the impact is negative: NGST<sup>§</sup> transistors are almost unaffected,

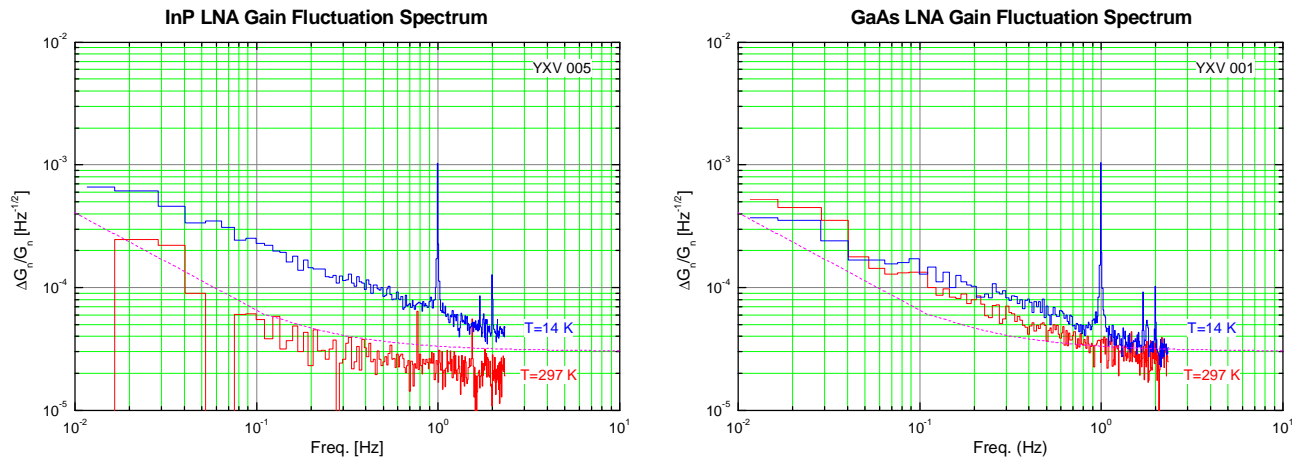

**Figure 4** Gain fluctuations spectra for two identical amplifiers with InP and GaAs devices respectively. The room temperature spectrum of the InP amplifier lies below the calibration spectrum of the normalized gain fluctuations of the measurement system. The lines appearing at 1 and 2 Hz are due to the refrigerator cycle, and the one at 1.7 Hz is probably related with mechanical vibrations of the vacuum pump.

<sup>†</sup> This ETH transistor is unpassivated. Unpassivated devices have usually higher 1/f noise.

<sup>‡</sup> Fujitsu Compound Semiconductor, Inc. (<http://www.fcsi.fujitsu.com>).

<sup>§</sup> Northrop Grumman Corporation (<http://www.northropgrumman.com>), formerly TRW.

but Fujitsu and ETH\*\* devices worsen by a factor of  $\sim 1.5$ . Measurements of other ETH batches at very low bias yield better results in darkness (similar to GaAs) but even worse results under illumination, with an increase of the fluctuations by a factor of 5 to 12.

Finally, we will briefly analyze the frequency dependence of noise and fluctuations. On one hand, the noise temperature increases lineally with frequency. As a rule of thumb, for narrow band high frequency amplifiers with InP devices, the noise temperature is about one half of the frequency in GHz. Table 3 presents three study cases of wide band amplifiers from 4 to 26 GHz, designed for the IF of ALMA and HIFI and the 22 GHz receiver of our 40m telescope. In these LNAs the rule applies roughly for the upper end of the band. On the other hand, the gain fluctuations do not depend directly on the frequency at which the amplifier operates. The fact that spectral density of the fluctuations at 1 Hz seems to increase with frequency is due to other factors that will be explained in the next sections, like the fact that the YK22 amplifier is biased very high.

AMPLIFIER	BAND [GHz]	STAGES	DEVICES	NOISE [K]	GAIN [dB]	GAIN FLUCTUATIONS	
						b [Hz <sup>-1/2</sup> ]	$\alpha$
YCA 2	4 - 8	3	2 × NGST CRYO4	3.5	39.2	7.8E-5	0.64
YXF 0	8-12	2	NGST 160 + FHX13X	6.5	21.9	10E-5	0.58
YK22	18 - 26	3	NGST CRYO3 + 2 × NGST 160	8.9	26.1	13E-5	0.43

**Table 3** Comparison of the noise temperature and gain fluctuations performance of wide band amplifiers with InP devices at different frequency bands. Gain fluctuation parameters follow equation 5. The apparent frequency dependence of b is driven mainly by the different bias at which the noise temperature is optimized.

### 3.2. Statistical analysis of long series results

During the development phase of Herschel and ALMA projects, many cryogenic amplifiers were fabricated in our labs. This gave us the opportunity to take long measurement series of some statistical significance. We present here the results at cryogenic temperatures of two different amplifier models, both designed for the 4 to 8 GHz frequency range. The first of them is the Development Model for the HIFI instrument (HIFI-DM). We will consider in this section the results of the 9 amplifiers of this type delivered to the instrument consortium (SRON) to build the DM receiver. The LNAs have two stages with NGST transistors of IREL1 batch (see Figure 3). The second model is being produced for the ALMA bands 7 and 9. A total of 10 units have been delivered to IRAM and NOVA to be integrated in the prototype receivers. These amplifiers have three stages and a perfected design, based on HIFI-DM but without the constraints of the space qualification requirements. The transistors employed are NGST – CRYO4 batch for the first stage and ETH – IRAM3 batch for the second and third (see Figure 4). All the transistors mentioned are based on InP, passivated, and with gate dimensions of 200×0.1  $\mu\text{m}$  for NGST and 150×0.2  $\mu\text{m}$  for ETH.

The noise and gain plots are presented in Figure 1 and Figure 2. They show similar temperatures, around 3 to 4 K, and a flatter and higher gain for the ALMA design, as a consequence of its three stages. The area defined by the colored bands contains the curves of all the amplifiers of each series. It is remarkable the repeatability of both series. As a measure of the dispersion of the noise temperature values (average in the band) we use in Table 3 and Table 4 the standard deviation normalized with respect to the average of all the amplifiers. The results are slightly better for the ALMA LNAs (5% dispersion compared to 7% for HIFI-DMs), but the difference is not very significant for this relatively small amount of data. The very low noise values and excellent repeatability is a consequence of a good design (paying special attention to cryogenic device modeling and sensitivity to fabrication parameters), extremely careful mounting techniques and exceptional transistors. The noise performance of the first stage devices (NGST IREL1 and CRYO4) is very similar as derived from measurements taken of a DM with each transistor.

\*\* Laboratory for Electromagnetic Fields and Microwave Electronics, Swiss Federal Institute of Technology, Zürich, Switzerland.

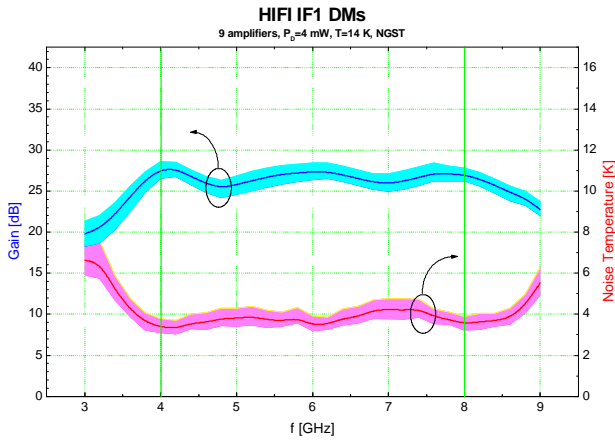

**Figure 1** Cryogenic noise and gain plots of 9 DMs built for HIFI. The colored bands are defined by worst and best values for all the amplifiers. The solid line is the average of the series.

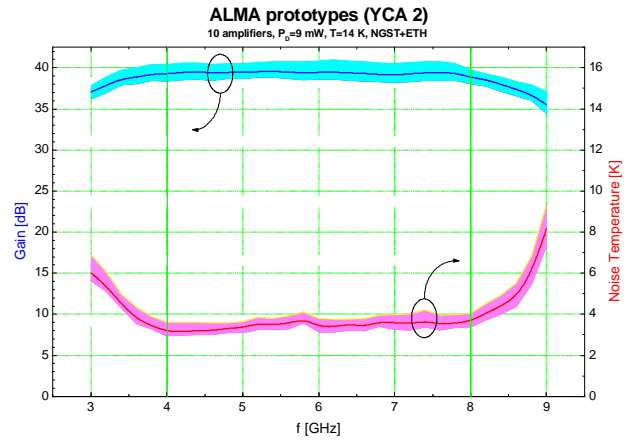

**Figure 2** Cryogenic noise and gain plots of 10 ALMA amplifiers, in the same fashion as Figure 1.

AMPLIFIER YCF	GAIN FLUCT. @ 1Hz ( $b$ )	SPECTRAL INDEX ( $\alpha$ )
6004	8.62E-05	0.754
6005	8.88E-05	0.706
6006	8.58E-05	0.332
6007	14.5E-05	0.430
6009	10.0E-05	0.726
6010	8.69E-05	0.415
6011	11.4E-05	0.324
6012	9.03E-05	0.429
6014	10.2E-05	0.762

**Table 1** Gain fluctuation data at 14 K for HIFI-DMs according to equation 5.

$x$	MIN.	MAX.	$\bar{x}$	$s / \bar{x}$
$T_N$ [K]	3.4	4.2	<b>3.78</b>	<b>0.076</b>
$b$ [Hz <sup>-1/2</sup> ]	8.58E-5	14.5E-5	<b>9.99E-5</b>	<b>0.194</b>
$\alpha$	0.321	0.762	0.542	0.351

**Table 3** Summary of cryogenic noise and fluctuations results for 9 HIFI-DMs. Gain fluctuations data comes from Table 1; noise temperature is the average in the band for each amplifier. Compare the dispersion values, represented by the normalized standard deviation.

AMPLIFIER YCA	GAIN FLUCT. @ 1Hz ( $b$ )	SPECTRAL INDEX ( $\alpha$ )
2003	7.43E-05	0.668
2004	7.65E-05	0.690
2005	7.91E-05	0.606
2006	7.51E-05	0.731
2007	7.04E-05	0.640
2008	8.72E-05	0.647
2009	8.61E-05	0.633
2010	8.39E-05	0.588
2011	7.21E-05	0.639
2012	7.13E-05	0.606

**Table 2** Gain fluctuation data at 14 K for ALMA amplifiers according to equation 5.

$x$	MIN.	MAX.	$\bar{x}$	$s / \bar{x}$
$T_N$ [K]	3.2	3.8	<b>3.46</b>	<b>0.051</b>
$b$ [Hz <sup>-1/2</sup> ]	7.04E-5	8.72E-5	<b>7.76E-5</b>	<b>0.080</b>
$\alpha$	0.588	0.731	0.645	0.066

**Table 4** Summary of cryogenic noise and fluctuations results for 10 ALMA amplifiers, in the same fashion as Table 3. Note the significant reduction of the dispersion of gain fluctuation variables, compared to HIFI data.

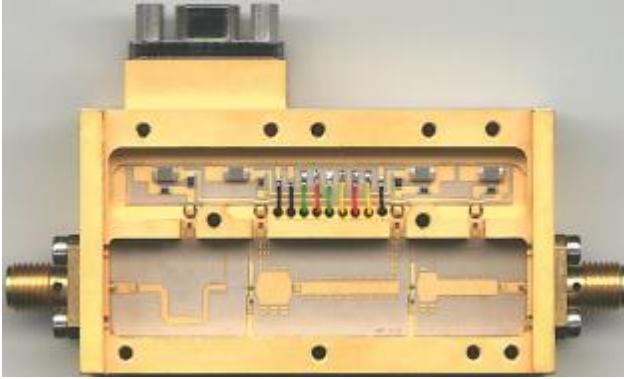

**Figure 3** 2-stages 4-8 GHz HIFI cryogenic LNA Development Model (DM) YCF 6. Amplifier size is 58×32×15 mm.

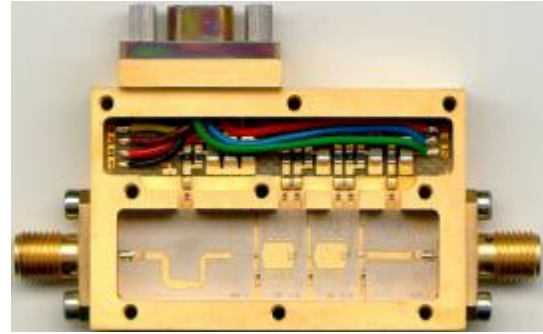

**Figure 4** 3-stages 4-8 GHz cryogenic LNA prototype for ALMA band 7. Amplifier size is 46×29×9 mm.

Nevertheless, the gain fluctuations data shown in Table 1 and Table 2 yield more interesting conclusions. The numbers included correspond to the values of the normalized gain fluctuations spectral density at 1 Hz (b) and the corresponding spectral index ( $\alpha$ ), as explained in section 2.2. The spectra were taken at 6 GHz. The fluctuations at 1 Hz are around  $10^{-4} \text{ Hz}^{-1/2}$ , again slightly better for the ALMA LNAs even though it has one stage more. Note that the 2<sup>nd</sup> and 3<sup>rd</sup> stages of ALMA design have ETH transistors with larger gate area, whose contribution to the overall fluctuations should be smaller than those of the NGST device of the 2<sup>nd</sup> stage of HIFI-DMs (the fluctuations of the first stage devices are a little better for the NGST CRYO4 than for IREL1, as derived from the previously mentioned measurements, and the bias point is a bit lower – see next section). But the main difference comes out in the dispersion (Table 3 and Table 4), where ALMA LNAs remain quite stable (8% variation), while the values for HIFI-DMs are very scattered (19% around the average). The reasons for this are not very clear, although it is likely that it could be related with the device characteristics and the manufacturing processes of each batch. The wider scattering of the parameters of IREL1 lot is also evident in the bias data. The bias conditions set by the operator (voltage and drain current) are very homogeneous in each series, but the gate voltage values driven by the power supply<sup>††</sup> are much less scattered in the amplifiers with CRYO4 devices (6% for CRYO4 against 44-88% for IREL1). The spectral index results show the same behavior, although they have to be treated with caution, as the frequency range available with our measurement system to fit this parameter (one decade) was small. The average of each series is higher than the value of 0.5 reported by Wollack<sup>16</sup>. This high scattering has been observed in other transistor batches. We can conclude that some batches of transistors present a wide dispersion in gain fluctuations not seen in noise, while others are much more homogeneous.

### 3.3. Bias conditions considerations

We have already mentioned the sensitivity of gain fluctuations to variations of the bias point. Small changes in drain current and especially in drain voltage may lead to significant variations in the fluctuations. The cryogenic noise temperature response to bias changes is much smoother. This behavior can be observed in Figure 5, where for drain voltages of the first stage NGST CRYO4 transistor below ~0.5 V the fluctuations decrease steeply, particularly for the low drain currents typically used in InP devices. In the same bias range (0.4 – 0.5 V) where the fluctuations multiply by 3, the noise temperature hardly changes a few tenths of a degree. It is also noticeable that the fluctuations are inversely related to the drain current, at least for high drain voltages. Measurements of other batches of NGST devices confirm these phenomena. Traditionally, the bias point of cryogenic amplifiers has been optimized for noise, and to a less extent, for flat gain and low return losses. Gain fluctuations measurements are very time consuming and it is not practical to optimize the bias of each device for this parameter. It is important to take into account how easily we may bias the amplifier into a region of high fluctuations during this tuning process, moreover when we may obtain much lower fluctuations with a very low penalty in noise.

<sup>††</sup> Our power supply for the HEMTs adjusts the gate voltage to maintain constant the selected drain current, with a loop bandwidth of around 100 Hz. We have verified that this approach yields slightly better gain fluctuations than keeping a constant gate voltage as proposed by Jarosik<sup>17</sup>.

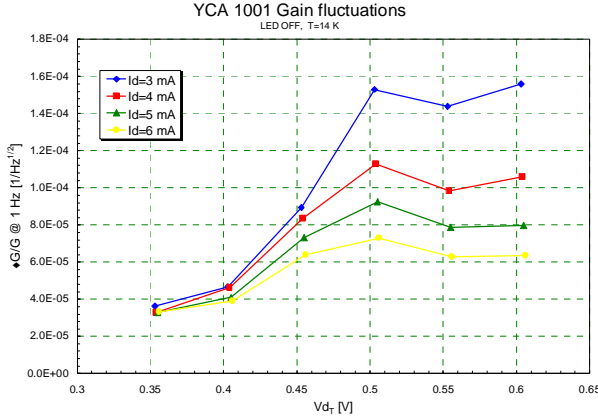

**Figure 5** Measurements of the cryogenic normalized gain fluctuations (b parameter) response of a 3-stages 4-8 GHz amplifier to changes in the bias point of the 1<sup>st</sup> stage. There is an InP device in the 1<sup>st</sup> stage and two GaAs transistors in the 2<sup>nd</sup> and 3<sup>rd</sup>. This variation of bias produces only minor modifications of the noise performance.

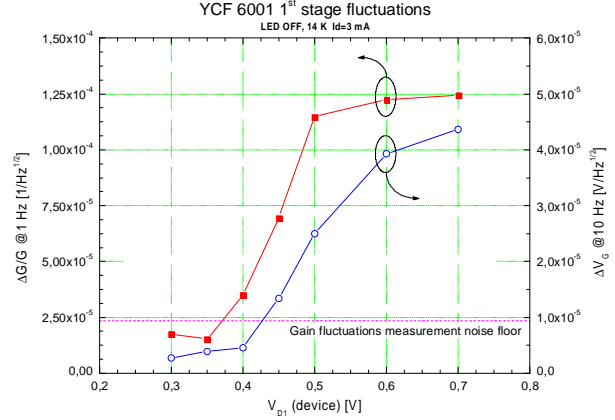

**Figure 6** Measurements of the variation with drain voltage of fluctuations in gain and gate voltage in the 1<sup>st</sup> stage of a HIFI-DM. A correlation is apparent. The values of gain stability for the lower drain voltages are contaminated by system noise.

We also measured in some amplifiers the gate voltage fluctuations with an HP35670A Dynamic Signal Analyzer, to verify the correlation between fluctuations in bias and gain. The reference parameter for the voltage fluctuations is the spectral density at 10 Hz to be above the white noise level for low drain voltages. Note that with a feedback power supply as ours and within the servo bandwidth, we will actually be testing the drain current fluctuations. Figure 6 shows the bias and gate fluctuations for one NGST IREL1 device after sampling several drain voltages while keeping a fixed drain current. It is clear that a correlation exists between bias noise and gain fluctuations. The same steep variation with the drain voltage, slightly smoothed, is measured in the voltage fluctuations.

This relationship between bias noise and gain fluctuations could be useful to choose the best individual devices of a batch in terms of gain stability with simple DC measurements. This preselection of devices is important because, as we have shown, some batches of InP HEMTs are very inhomogeneous in the gain fluctuations parameters. The measurement of noise in gate voltages could be used to easily detect the high fluctuation zones. Bias noise measurements could also be a tool to identify the worse gain fluctuations bias.

#### 4. CONCLUSIONS

Our laboratories have specialized in the design, fabrication and measurement of low noise cryogenic amplifiers. We present here the specific measurement techniques to characterize them. We have had an early access to excellent InP devices and pioneered its application in IF amplifiers. Recently, the demand of wider instantaneous IF bands has made the effect of gain fluctuations more prominent. Some preliminary tests confirmed that while the microwave noise performance improves with InP device technology at low temperatures, gain fluctuations are a problem respect to previous technologies and should be carefully characterized. Long series of cryogenic measurements from 20 of the LNAs delivered to ALMA and HIFI (Herschel) were presented, where octave band IF amplifiers based on InP transistors with excellent noise temperature (3.5 K) and remarkable repeatability have been demonstrated. It was also shown that the fluctuations in gain are, on the contrary, very scattered between transistors of the same batch, but only for certain batches. Comparing the optimum bias for noise and fluctuations, we found a much stronger dependence of the gain fluctuations with the drain voltage, and to a lesser extent, with the drain current. Small variations of the bias point with negligible impact in the noise performance may lead to significant variations of the gain fluctuations. Finally, a correlation between the gain fluctuations and the device bias noise was established, which may allow to use the more straightforward bias noise measurements as a tool to reject noisy devices or detect the dangerous bias zones.

## ACKNOWLEDGEMENTS

This research was supported in part by the Spanish Administration grants ESP2001-04519-PE, ESP2002-01693, ALMA2002-01050E and AYA2003-07584 (Ministerio de Ciencia y Tecnología). NGST InP transistors used in this project were developed in the Cryogenic HEMT Optimization Program funded under NASA Code R Enabling Concepts and Technologies Program. The authors would also like to acknowledge ETH (Laboratory for Electromagnetic Fields and Microwave Electronics, Swiss Federal Institute of Technology, Zürich, Switzerland) for providing the devices used in many amplifiers during the course of Herschel and ALMA projects.

## REFERENCES

1. <http://www.sron.nl/divisions/lea/hifi/index.html>
2. <http://www.alma.nrao.edu/>  
<http://www.eso.org/projects/alma/>
3. J.C Webber, M.W Pospieszalski, "Microwave Instrumentation for Radio Astronomy", IEEE Trans. Microwave Theory Tech., vol. 50 pp. 1705-1711, Mar. 2002.
4. M. W. Pospieszalski, W. J. Lakatos, E. Wollack, L. D. Nguyen, L. Minh, M. Lui, L. Takyiu, "Millimeter-wave waveguide-bandwidth cryogenically-coolable InP HEMT amplifiers", 1997 IEEE MTT-S Int. Microwave Symp. Digest, pp. 1285-1288.
5. I. López-Fernández, C. Diez, J. D. Gallego, A. Barcia, "Wide Band Cryogenic IF Amplifiers for ALMA and Herschel Receivers", Proc. of the 14<sup>th</sup> Int. Symp. on Space TeraHertz Technology, Tucson (Az, USA), April 2003.
6. I. López-Fernández, J. D. Gallego, C. Diez, A. Barcia, J. M. Pintado, "Wide Band, Ultra Low Noise Cryogenic InP IF Amplifiers for the Herschel Mission Radiometers", Millimeter and Submillimeter Detectors for Astronomy, Proc. SPIE vol. 4855, pp. 489-500, 2003.
7. N. Wadefalk, A. Mellberg, I. Angelov, E. Choumas, E. Kollberg, N. Rorsman, P. Starski, J. Stenarson, H. Zirath, R. Lai, R. Grundbacher, M. Barsky, S. Bui and D. Streit, "Cryogenic, Wideband, Ultra-Low Noise IF-Amplifiers Operating at Ultra-Low Dc-Power", IEEE Trans. Microwave Theory Tech., vol. 51, pp. 1705-1711, Jun. 2003.
8. J. D. Gallego and M.W. Pospieszalski, "Accuracy of Noise Temperature Measurement of Cryogenic Amplifiers", Electronics Division Internal Report No. 285, National Radio Astronomy Observatory, Charlottesville, VA, Mar. 1990.
9. S.-K. Pan, A. R. Kerr, M. J. Feldman, A. W. Kleinsassera, J. Stasiaks, R. L. Sandstroms, and W. J. Gallagher, "An SIS Mixer for 85-116 GHz Using Inductively Shunted Edge-junctions", IEEE Trans. Microwave Theory Tech., vol. 37, pp. 580-592, Mar. 1989.
10. W. R. McGrath, A. V. Raisänen and P. L. Richards, "Variable Temperature Loads for Use in Accurate Noise Measurements of Cryogenically Cooled Microwave Amplifiers and Mixers", International Journal of Infrared and Millimeter Waves, vol. 7, no.4, 1986, pp. 543-553.
11. "Noise Figure Measurement Accuracy", Hewlett Packard Application Note 57-2.
12. C. T. Stelzried, "Temperature Calibration of Microwave Thermal Noise Sources", IEEE Trans. Microwave Theory Tech., vol. 13, pp. 128, Jan. 1965.
13. C. T. Stelzried, "Microwave Thermal Noise Standards", IEEE Trans. Microwave Theory Tech., vol. 16, pp. 646-655, Sep. 1968.
14. D. W. Allan, "Statistics of Atomic Frequency Standards", Proc. IEEE, vol. 54, no. 2, pp. 221-230, Feb. 1966.
15. J. W. Kooi, G. Chattopadhyay, M. Thielman, T.G. Phillips and R. Schieder, "Noise Stability of SIS Receivers", Int. J. Infrared Millimeter waves, vol. 21, no. 5, pp. 689-716, May 2000.
16. E. J. Wollack and M. W. Pospieszalski. "Characteristics of broadband InP millimeter-wave amplifiers for radiometry." 1998 IEEE MTT-S Int. Microwave Symp. Digest 98.2, no. 2, pp. 669-672.

17. N. C. Jarosik. "Measurements of the Low-Frequency-Fluctuations of a 30-GHz High-Electron-Mobility-Transistor Cryogenic Amplifier", *IEEE Trans. Microwave Theory Tech.*, vol. 44.2, pp. 193-197, Feb. 1996.
18. M. D. Seifert, J. D. Gallego, I. Lopez Fernandez, N. D. Whyborn, J. C. Pearson, "IF Amplifier Stability for the Heterodyne Instrument for FIRST (HIFI)", *UV, Optical and IR Space Telescopes and Instruments*, Proc. SPIE vol. 4013, 2000.
19. J. D. Gallego, I. López-Fernández, "Measurements of Gain Fluctuations in GaAs and InP Cryogenic HEMT Amplifiers", Technical Report CAY 2000-1, Feb. 2000.